



INSTALLATION AND OPERATION MANUAL

Condensing dehumidifier
Condair DC 75 / DC 100 / DC 150 / DC 200

Thank you for choosing Condair

Installation date (MM/DD/YYYY):

Commissioning date (MM/DD/YYYY):

Site:

Model:

Serial number:

Proprietary Notice

This document and the information disclosed herein are proprietary data of Condair Group AG. Neither this document, nor the information contained herein shall be reproduced, used, or disclosed to others without the written authorisation of Condair Group AG, except to the extent required for installation or maintenance of recipient's equipment.

Liability Notice

Condair Group AG does not accept any liability due to incorrect installation or operation of the equipment or due to the use of parts/components/equipment that are not authorised by Condair Group AG.

Copyright Notice

© Condair Group AG, All rights reserved.

Technical modifications reserved.

INDEX

1. INTRODUCTION	5
1.1 Preliminary information	5
1.2 Aim and content of the manual	5
1.3 How to store this manual	5
1.4 Manual Update	5
1.5 How to use this manual	5
1.6 Potential Risks	6
1.7 General Description of Symbols Used	7
1.8 Safety symbols used	8
1.9 Limitations and prohibited use	8
1.10 Unit identification	9
2. SAFETY	10
2.1 Warning re potentially hazardous toxic substances	10
2.2 Refrigerant handling	10
2.3 Prevent inhalation of high vapor concentration	11
2.4 Procedures to be adopted in the event of accidental release of refrigerant	11
2.5 Main Toxicological Information Regarding the Type of refrigerant used	11
2.6 First Aid Measures	11
3. TECHNICAL CHARACTERISTICS	12
3.1 Unit description	12
3.2 Accessories	13
3.3 Technical data	14
3.4 Operation limits	18
3.5 Sound data	19
3.6 Safety devices	19
4. INSTALLATION	20
4.1 General safety guidelines and use of symbols	20
4.2 Health and safety Considerations	20
4.3 Personal protective equipment	20
4.4 Inspection	21
4.5 Storage	21
4.6 Unpacking	21
4.7 Lifting and handling	21
4.8 Location and minimum technical clearances	22
4.9 Condensate draining connections	22
4.10 How to remove filters	23
4.11 Installation of built-in room electronic sensor (RGDD)	24
4.12 Serial interface card RS485 (INSE)	24
4.13 Connecting the unit to air duct channels	25
4.14 Fan positioning	26
4.15 Remote mechanical hygostat installation (HYGR)	26
4.16 Electric connections: preliminary safety information	28
4.17 Electrical data	29
4.18 How to connect the power supply	29
4.19 Electric connections	30
4.20 Refrigerant circuit layout	31
5. UNIT START UP	31
5.1 Preliminary checks	31
5.2 Description of the control panel	32
5.3 Remote control panel	33
6. USE	35
6.1 Switch the unit on	35
6.2 Stop	37
6.3 Stand-by	37
6.4 How to change the set points	37

6.5 Acoustic signal silencing	38
6.6 Display during alarm	38
6.7 Alarm reset.....	38
7. MAINTENANCE OF THE UNIT	39
7.1 General warnings.....	39
7.2 Drive access	40
7.3 Scheduled maintenance	40
7.4 Periodical checks.....	40
7.5 Refrigerant circuit repair	42
8. DECOMMISSIONING.....	43
8.1 Disconnect the unit	43
8.2 Disposal, recovery and recycling	43
8.3 RAEE Directive (only UE).....	43
9. DIAGNOSIS AND TROUBLESHOOTING	44
9.1 Fault finding	44
10. DIMENSIONAL DRAWINGS	45
11. EU DECLARATION OF CONFORMITY	49
12. MAINTENANCE AND SERVICE REPORT	50

1. INTRODUCTION

1.1 Preliminary information

Reproduction, storage or transmission of any part of this publication in any form, without the prior written consent of the Company, is prohibited.

The unit to which these instructions refer, is designed to be used for the the purposes described and to be operated in accordance with these instructions.

The Company will not be liable for claims for damage caused to persons, animals, material goods or property caused by improper installation, adjustment and maintenance or improper use. Any use not specified in this manual is prohibited.

This document is intended to provide information only and does not form a contract with third parties.

The Company pursues a policy of constant improvement and development of its products and therefore reserves the right to change the specifications and the documentation at any time, without notice and without obligation to update existing equipment.

1.2 Aim and content of the manual

These instructions are intended to provide the information required for the selection, installation, use and maintenance of the unit.

They have been prepared in accordance with the European Union laws and with the technical standards in force at the date of issue of the instructions.

The instructions contain all the necessary information to prevent any reasonably foreseeable misuse.

1.3 How to store this manual

The manual must be kept in a suitable place with easy access for users and operators, protected from dust and damp.

The manual must always accompany the unit during the entire life cycle of the same and therefore must be transferred to any subsequent user.

1.4 Manual Update

It is recommended that the manual is updated to the latest revision available.

If updates are sent to the customer they must be added to this manual.

The latest information regarding the use of its products is available by contacting the Company.

1.5 How to use this manual



The manual is an integral part of the unit.

Users or operators must consult the manual before performing any operation and especially so when transporting, handling, installing, maintaining, or dismantling the unit in order to eliminate uncertainty and reduce risk.



In these instructions symbols have been used (described in the following paragraphs) to draw the attention of operators and users to the operations that have a higher risk and which must be performed safely.

1.6 Potential Risks

Whilst the unit has been designed to minimize any risk posed to the safety of people who will interact with it, it has not been technically possible to eliminate completely the causes of risk. It is therefore necessary to refer to the requirements and symbolism below:

LOCATION OF RISK	POTENTIAL RISK	METHOD OF INJURY	PRECAUTIONS
Thermal heat exchangers.	Small stab wounds.	Contact	Avoid any contact, use protective gloves.
Fan and fan grilles.	Cuts, eye damage, broken bones.	Insertion of sharp objects through the grid while the fans are operating.	Never put objects through the protection grilles.
Internal component: compressors and discharge pipes	Burns.	Contact	Avoid any contact, use protective gloves.
Internal component: electric cables and metallic parts	Electrocution, severe burns.	Defect in the supply cable insulation, live metallic parts.	Adequate protection of power cables, ensure correct earthing of all metal parts.
External to unit: unit enclosure	Poisoning, severe burns.	Fire due to short circuit or overheating of the supply cable external to unit.	Size cables and mains protection system in accordance with iee regulations.
Low pressure safety valve.	Poisoning, severe burns.	High evaporating pressure causing a refrigerant discharge during maintenance.	Carefully check the evaporating pressure during the maintenance operations. Use all personal protective equipment required by the law. PPE must also protect against gas leaks from the safety valve. The outlet of these valves is directed to avoid causing damage to persons or goods.
High pressure safety valve.	Poisoning, severe burns, hearing loss.	Activation of the high pressure safety valve with the refrigerant circuit open.	If possible, do not open the refrigerant circuit valve; carefully check the condensing pressure; use all the personal protective equipment required by law. PPE must also protect against gas leaks from the safety valve. The outlet of these valves is directed to avoid causing damage to persons or goods.
Entire unit	External fire	Fire due to natural disasters or combustions of elements nearby unit	Provide the necessary fire-fighting equipment
Entire unit	Explosion, injuries, burns, poisoning, folgoramento for natural disasters or earthquake.	Breakages, failures due to natural disasters or earthquake	Plan the necessary precautions both electrical (suitable differential magneto and electrical protection of the supply lines; greatest care during the connections of the metal parts), and mechanical (special anchors or seismic vibrations to prevent breakages or accidental falls).

1.7 General Description of Symbols Used

Safety symbols combined in accordance with ISO 3864-2:



BANNED

A black symbol inside a red circle with a red diagonal indicates an action that should not be performed.



WARNING

A black graphic symbol added to a yellow triangle with black edges indicates danger.



ACTION REQUIRED

A white symbol inserted in a blue circle indicates an action that must be done to avoid a risk.

Safety symbols combined in accordance with ISO 3864-2:



The graphic symbol "warning" is qualified with additional safety information (text or other symbols).

1.8 Safety symbols used



GENERAL RISK

Observe all signs placed next to the pictogram. The failure to follow directions may create a risk situation that may be injurious to the user.



ELECTRICAL HAZARD

Observe all signs placed next to the pictogram. The symbol indicates components of the unit and actions described in this manual that could create an electrical hazard.



MOVING PARTS

The symbol indicates those moving parts of the unit that could create risk.



HOT SURFACES

The symbol indicates those components with high surface temperature that could create risks.



SHARP SURFACES

The symbol indicates components or parts that could cause stab wounds.



EARTH CONNECTION

The symbol identifies Earthing connection points in the unit.



READ AND UNDERSTAND THE INSTRUCTIONS

Read and understand the instructions of the machine before any operations.



RECOVER OR RECYCLE MATERIAL

1.9 Limitations and prohibited use

The machine is designed and built exclusively for the uses described in "Limitations of use" of the technical manual. Any other use is prohibited because it may pose a potential risk to the health of operators and users.



The unit is not suitable for operations in environments:

- excessively dusty or potentially explosive atmospheres;
- where there are vibrations;
- where there are electromagnetic fields;
- where there are aggressive atmospheres

1.10 Unit identification

Each unit has a rating plate that provides key information regarding the machine. The rating plate may differ from the one shown below as the example is for a standard unit without accessories. For all electrical information not provided on the label, refer to the wiring diagram. An image of the label is shown below:

		Manufacturer: PD322111	
Condair Group AG, Gwattstrasse 17, 8808 Pfäffikon Switzerland			
1DC0.075S-2		123456	
Modello Model		Matricola Serial number	
1		8/2017	
Categoria PED PED Category		Data di fabbricazione Manufacture date	
R410A	2	2088	
Tipo refrigerante Refrigerant type	Gruppo fluido Fluid group	GWP	
C1 0,55 Kg	C2	1,15 ton	
C3	C4		
Carica refrigerante Refrigerant charge		CO ₂ Equivalente CO ₂ Equivalente	
230V-1ph-50Hz		5,5 A	1,2 kW
Tensione-Fasi-Frequenza Voltage-Phases-Frequency		F.L.A. (A)	F.L.I. (kW)
LATO BASSA PRESSIONE LOW PRESSURE SIDE		LATO ALTA PRESSIONE HIGH PRESSURE SIDE	
22 bar		42 bar	
PS		PS	
Min	Max	Min	Max
-30 °C	+130 °C	-30 °C	+130 °C
Temperatura di progetto Design temperature		Temperatura di progetto Design temperature	
85 Kg			
Peso a vuoto Weight			
Contiene gas fluorurati ad effetto serra disciplinati dal protocollo di Kyoto Contains fluorinated greenhouse gasses covered by the Kyoto protocol			
			



The product label should never be removed from the unit.

2. SAFETY

2.1 Warning re potentially hazardous toxic substances

2.1.1 Identification of the Type of Refrigerant Fluid Used: R410A

- Difluoromethane (HFC-32) 50% by weight CAS No.: 000075-10-5
- Pentafluoroethane (HFC-125) 50% by weight CAS No.: 000354-33-6

2.1.2 Identification of the Type of Oil Used.

The lubricant used is polyester oil. Please refer to the information provided on the compressor data plate.



For further information regarding the characteristics of the refrigerant and oil used, refer to the safety data sheets available from the refrigerant and oil manufacturers.

Main Ecological Information Regarding the Types of refrigerants Fluids used.



ENVIRONMENTAL PROTECTION : Read the ecological information and the following instructions carefully.

2.1.3 Persistence and degradation

The refrigerants used decompose in the lower atmosphere (troposphere) relatively quickly. The decomposed products are highly dispersible and therefore have a very low concentration. They do not influence the photochemical smog which is not among the VOC volatile organic compounds (as stipulated in the guidelines to the UNECE). The constituent refrigerants of R410A (R32 and R125), do not damage the ozone layer. These substances are regulated under the Montreal Protocol (revised 1992) and regulations EC no. 2037/200 of 29 June 2000.

2.1.4 Effects of discharges

Discharges into the atmosphere of this product does not cause a long-term contamination.

2.1.5 Exposure controls and personal protection

Wear protective clothing and gloves, protect your eyes and face

2.1.6 Permissible exposure limit

R410A

HFC-32 TWA 1000 ppm

HFC-125 TWA 1000 ppm

2.2 Refrigerant handling



Users and maintenance personnel must be adequately informed about the possible risks of handling potentially toxic substances. Failure to follow such instructions can cause damage to personnel or to the unit.

2.3 Prevent inhalation of high vapor concentration

Atmospheric concentrations of refrigerant must be minimized and kept to a level that is below the occupational exposure limit. Vapor is heavier than air and can form dangerous concentrations near the ground where the ventilation rate is lower. Always ensure adequate ventilation. Avoid contact with open flames and hot surfaces as this can cause toxic and irritating decomposition products to form. Avoid contact between liquid refrigerant and the eyes or skin.

2.4 Procedures to be adopted in the event of accidental release of refrigerant

Ensure suitable personal protection (especially respiratory protection) during cleaning operations.

If deemed safe, isolate the source of the leak. If the leakage is small and if adequate ventilation is provided, allow the refrigerant to evaporate. If the loss is substantial ensure that measures are taken to adequately ventilate the area.

Refrigerant remaining in the system should be recovered in an environmentally sound manner conforming to the EU F-Gas Regulations 2014. Contain spilled material with sand, earth or other suitable absorbent material.

Do not allow the refrigerant to enter drains, sewers or basements, as pockets of vapor can form.

2.5 Main Toxicological Information Regarding the Type of refrigerant used

2.5.1 Inhalation

A high atmospheric concentration can cause anaesthetic effects with possible loss of consciousness. Prolonged exposure may lead to irregular heartbeat and cause sudden death. Higher concentrations may cause asphyxia due to the reduced oxygen content in the atmosphere.

2.5.2 Contact with skin

Splashes of nebulous liquid can produce frostbite. Probably not hazardous if absorbed through the skin. Repeated or prolonged contact may remove the skin's natural oils, with consequent dryness, cracking and dermatitis.

2.5.3 Contact with eyes

Splashes of liquid may cause frostbite.

2.5.4 Ingestion

While highly improbable, may produce frostbite.

2.6 First Aid Measures



Adhere scrupulously to the warnings and first aid procedures indicated below.

2.6.1 Inhalation

Move the person away from the source of exposure, keep him/her warm and let him/her rest. Administer oxygen if necessary. Attempt artificial respiration if breathing has stopped or shows signs of stopping. If the heart stops, perform external heart massage. Seek medical assistance.

2.6.2 Contact with skin

In case of contact with skin, wash immediately with lukewarm water. Thaw tissue using water. Remove contaminated clothing. Clothing may stick to the skin in case of frostbite. If irritation, swelling or blisters appear, seek medical assistance.

2.6.3 Contact with eyes

Rinse immediately using an eyewash or clean water, keeping eyelids open, for at least ten minutes. Seek medical assistance.

2.6.4 Ingestion

Do not induce vomiting. If the injured person is conscious, rinse his/her mouth with water and make him/her drink 200-300ml of water. Seek immediate medical assistance.

2.6.5 Further medical treatment

Treat symptoms and carry out support therapy as indicated. Do not administer adrenaline or similar sympathomimetic drugs following exposure, due to the risk of cardiac arrhythmia.

3. TECHNICAL CHARACTERISTICS

3.1 Unit description

Dehumidifiers series are high-performances units especially designed for industrial or commercial purposes where humidity level should be controlled or water vapor condensation should be prevented. These units are particularly indicated for archives, ironing rooms, bookstores, cheese factories, underground rooms, cellars and industrial sites where high humidity level is present. This series comprises 5 models which cover a capacity range from 73 to 240 l/24h. The units are designed for easy maintenance and service, each part being readily accessible and, when required, easily replaceable thus reducing service and maintenance costs. The units are supplied with a solenoid valves set for the hot gas injection used to defrost the evaporator in case of severe working conditions.

3.1.1 Frame

All units are made from hot-galvanised thick sheet metal, painted with polyurethane powder enamel at 180°C to ensure the best resistance against the atmospheric agents. The frame is self-supporting with removable panels. All screws and rivets are in stainless steel. The colour of the units is RAL 9006.

3.1.2 Refrigerant circuit

The refrigerant gas used in these units is R410A. The refrigerant circuit is made by using international primary brands components and according to ISO 97/23 concerning welding procedures. The refrigerant circuit includes: sight glass, filter drier, thermal expansion valve with external equalizer, Schrader valves for maintenance and control, pressure safety device (according to PED regulation). All the units are supplied with injection valves kit for hot gas defrost cycle.

3.1.3 Compressors

The compressors are rotative type, with thermal overload protection by a klixon embedded in the motor winding. The compressor is mounted on rubber vibration dampers and it is supplied, standard, with sound-proof cover to reduce noise emission. The inspection is possible through the frontal panel of the unit that allows the maintenance of the compressor.

3.1.4 Condenser and evaporator

Condensers and evaporators are made of copper pipes and aluminium fins. The diameter of the copper pipes is 3/8" and the thickness of the aluminium fins is 0,1 mm. The tubes are mechanically expanded into the aluminium fins to improve the heat exchange factor. The geometry of these heat exchangers guarantees a low air side pressure drop and then the use of low rotation (and low noise emission) fans. All evaporators are supplied with a temperature sensor used as automatic defrost probe.

3.1.5 Supply fan

The fans are made of galvanized steel, centrifugal type. It is statically and dynamically balanced and supplied. The electric motors are directly connected to the fan. The protection class of the motors is IP 54.

3.1.6 Air filter

It is made of synthetic filtering media, undulated type, without electro-static charge; they are all removable for differential disposal. Efficiency class ePM10 50%, according to EN 16890:2017.

3.1.7 Microprocessors

All units are supplied standard with microprocessor controls. The microprocessor controls the following functions: compressor timing, automatic defrost cycles, alarms. An appropriate LCD display shows the operation mode of the unit, set point and alarms.

3.1.8 Electric enclosure

The electric switch board is made according to electromagnetic compatibility norms CEE 73/23 and 89/336. The accessibility to the board is possible after removing the front panel of the unit and the OFF positioning of the main switch. The following components are also standard installed: main switch, magnetic-thermal switches (as a protection fans and compressors), control circuit automatic breakers, compressor contactors, fan contactors. The terminal board is supplied with voltage free contacts for remote ON-OFF and general alarm.

3.1.9 Control and protection devices

All units are supplied with the following control and protection devices: antifreeze protection sensor, high pressure switch with manual reset, low pressure switch with automatic reset, high pressure safety valve, compressor thermal overload protection, fans thermal overload protection.

3.1.10 Test

All the units are fully assembled and wired at the factory, the refrigerant circuit is pressure tested to check for leaks then evacuated and charged with the correct weight of R410a. They are all fully operational tested before shipment. They all conform to European Directives and are individually marked with the CE label and provided with Conformity Declaration.

3.2 Accessories description

3.2.1 Electronic temperature and humidity probe (RGDD)

Built-in Electronic temperature and humidity probe.

3.2.2 Remote mechanical hygostat (HYGR)

To be installed on the wall, it is supplied with a regulation knob and working range from 30% to 100% with precision of 3%.

3.2.3 Remote control panel (PCRL)

This panel can be mounted up to 50m (maximum) from the unit and replicates all of the control functions. It is connected using a twin cable of 0.5 mm sq section.

3.2.4 Serial interface card RS485 (INSE)

This interface card enables the controller to communicate with other devices using Modbus protocol.

3.2.5 E.C. Supply fan (V1CE)

The supply fan is a high performance centrifugal type, double inlet forward curved blades, directly coupled to the electric motor. The fan wheel and the scroll are made from hot galvanised thick sheet metal, painted with polyurethane powders, to ensure the best resistance against aggressive environments. The electric motor is a high efficiency DC brushless type with external rotor, to guarantee an ideal cooling of the windings and the absence of power lost due to pulleys and belt transmission. The fan is statically and dynamically balanced class 6,3 according to ISO1940. The electric motor has a separate electronic commutator (driver) and a speed modulation 0-10V, integrated PFC, burn out thermal protection (in case of considerable reduction of the power supply), protection degree IP54, serial interface card with modbus protocol RTU.

3.2.6 Air filter with frame for ducted installation (FARC)

Complete with efficiency class G5, according to EN 779:2002 air filter which can be removed by the side and frame for ducted installation.

3.2.7 Rubber vibration dampers (KAVG)

To be installed beneath the unit base and the ground to avoid the transmission of vibrations (and the noise) to the building.

3.2.8 Floor trolley version (TROL)

To facilitate dehumidifier handling where is placed.

3.2.9 Stainless steel frame (INOX)

It's used to ensure the best resistance against the atmospheric agents and the operation in aggressive environments. The frame is made of stainless steel AISI 304, self-supporting with removable panels to facilitate inspection and maintenance of internal components. All screws and rivets are in stainless steel.

3.3 Technical data

DC		75	100	150	200
Moisture removed at 30°C - 80%	l/24h	78,5	109,2	133,9	175,9
Moisture removed at 30°C - 60%	l/24h	56,3	77,9	105,9	140,5
Moisture removed at 27°C - 60%	l/24h	49,5	68,8	100,0	128,2
Moisture removed at 20°C - 60%	l/24h	35,4	49,1	73,0	91,2
Moisture removed at 10°C - 70%	l/24h	25,3	35,2	55,2	68,3
Nominal input power at 30°C-80%	kW	1,4	1,8	2,2	2,8
Maximum input power	kW	1,9	2,1	2,9	3,6
Maximum input current	A	7,9	9,6	13,0	16,7
Peak current	A	25,0	38,0	41,6	64,6
Air Flow	m ³ /h	800	1000	1500	1800
Available static pressure	Pa	50÷150	50÷150	50÷150	50÷150
Refrigerant		R410A	R410A	R410A	R410A
Refrigerant charge	Kg	2088	2088	2088	2088
Global warming potential (GWP)		0,55	0,55	1,10	1,10
Equivalent CO ₂ charge	t	1,15	1,15	2,30	2,30
Sound power ⁽¹⁾	dB(A)	59	61	67	69
Sound pressure ⁽²⁾	dB(A)	45	47	52	54
Power supply	V/Ph/Hz	230/1/50	230/1/50	230/1/50	230/1/50

Performances are referred to the following conditions:

(1) Sound Power level according to ISO 961, fan with available static pressure 50 Pa.

(2) Sound pressure level measured at 1 mt from the unit in free field conditions according to ISO 9614. fan with available static pressure 50 Pa.



The refrigerant data may change without notice. It is therefore necessary to refer always to the silver label placed on the unit.

3.3.1 AC fans

DC 75

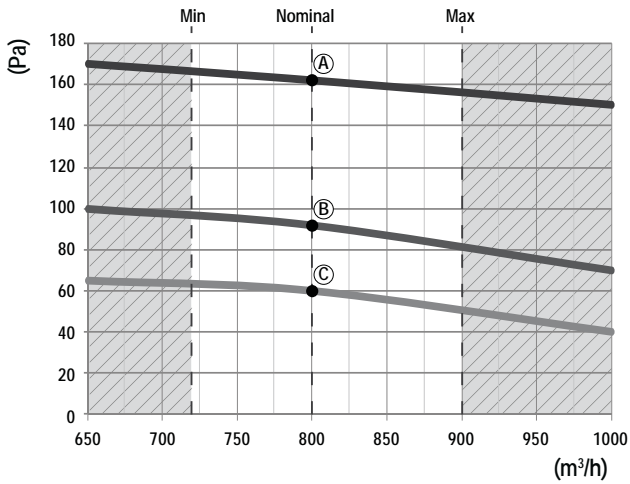

DC 100

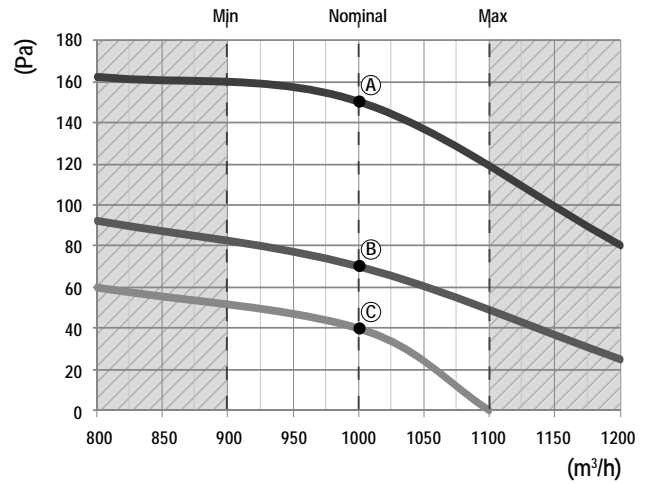

DC 150

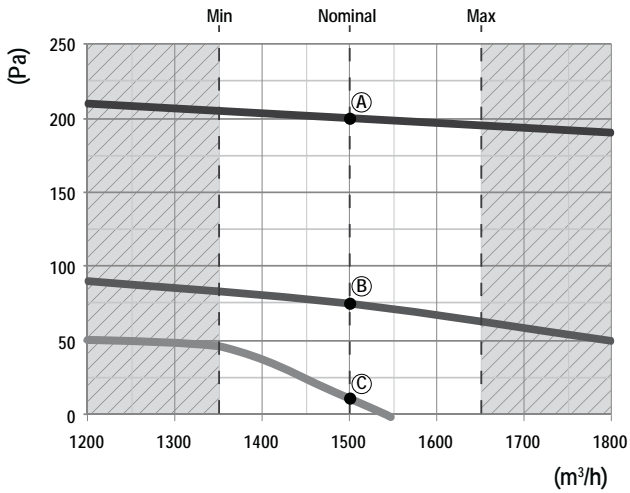

DC 200

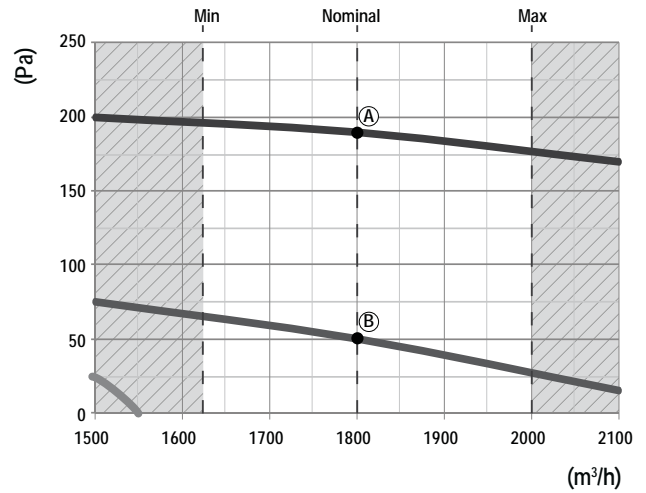

			075	100	150	200
A (High speed)	Input power	kW	0,20	0,25	0,42	0,44
	Input current	A	0,90	1,04	2,05	2,15
B (Medium speed)	Input power	kW	0,19	0,22	0,34	0,35
	Input current	A	0,85	1,00	1,65	1,72
C (Low speed)	Input power	kW	0,18	0,21	0,33	--
	Input current	A	0,80	0,92	1,6	--



In order to enable the proper functioning of the unit is important to ensure a constant air flow to the unit close to the nominal stated value. The maximum deviation allowed is 10%.

3.3.2 E.C. Supply fan (VECE) (accessory)

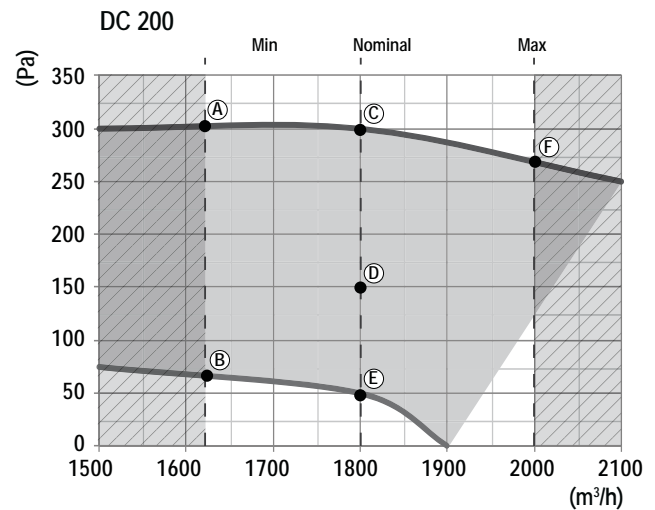
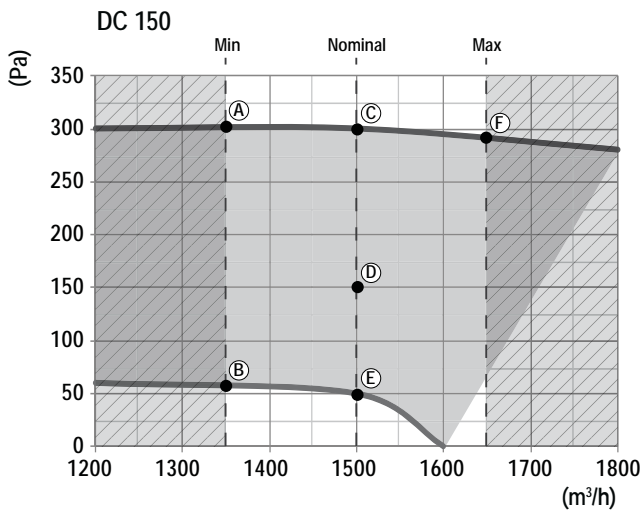
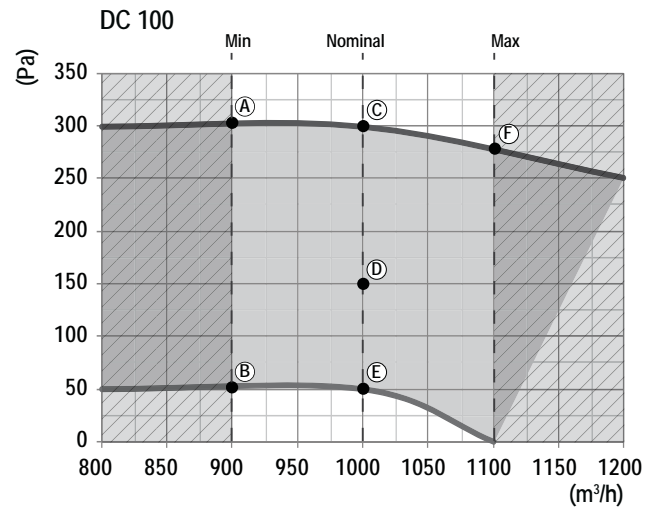
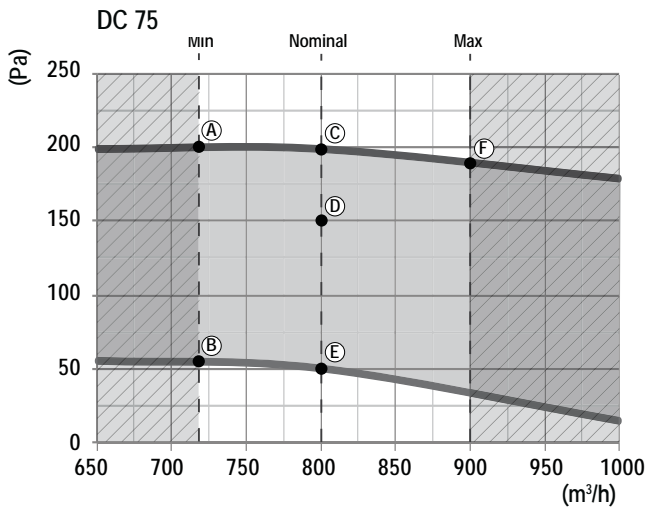

EC fan electrical data								
	075		100		150		200	
	kW	A	kW	A	kW	A	kW	A
A	0,13	0,60	0,24	1,00	0,32	1,40	0,40	1,70
B	0,07	0,40	0,08	0,40	0,14	0,07	0,21	0,90
C	0,15	0,70	0,26	1,10	0,37	1,60	0,44	1,90
D	0,12	0,50	0,15	0,60	0,22	0,90	0,30	1,30
E	0,07	0,40	0,09	0,40	0,16	0,70	0,22	0,90
F	0,14	0,60	0,25	1,10	0,37	1,60	0,48	2,00



In order to enable the proper functioning of the unit is important to ensure a constant air flow to the unit close to the nominal stated value. The maximum deviation allowed is 10%.

3.3.3 Supply fan Microswitches (Only with VECE)

All units equipped with EC fans are supplied with micro switches for the management of the speed of rotation. The micro switches configuration is done at the factory but can be modified by the user according to the specific plant requirements. Indicatively it can be considered that the displacement of the micro switch from one number to the next or previous leads to an increase/decrease of the available static pressure of about $30 \div 50$ Pa at nominal air flow.



All units are factory set with the nominal air flow rates and available static pressure of 150 Pa .

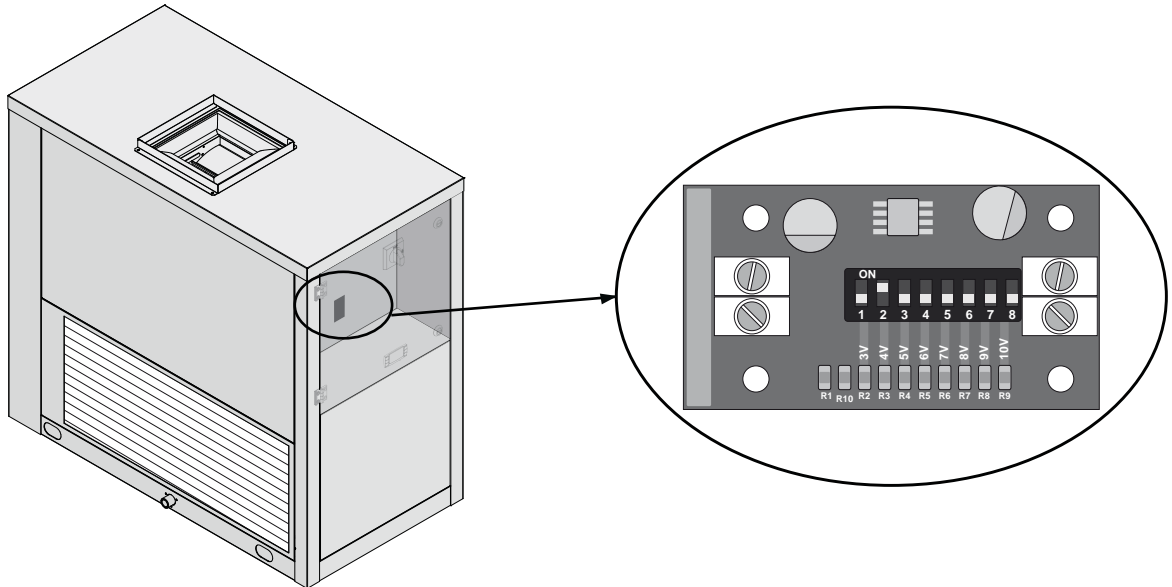

3.3.4 Fan speed setting

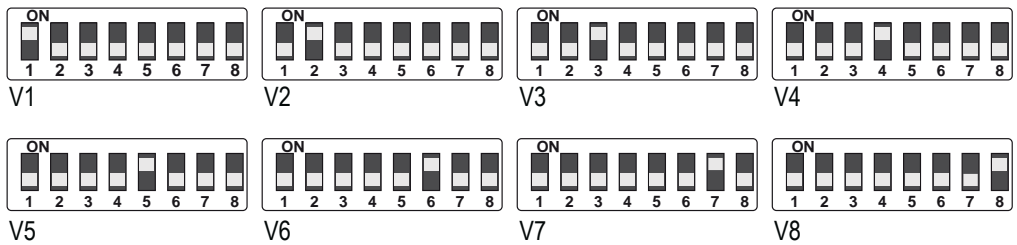

V1 = Minimum speed V8 = Maximum speed



The use of the minimum speed (1 and 2) must be carefully evaluated by skilled personnel because the operation at very low fan speed could result in malfunction or even damage to the unit.

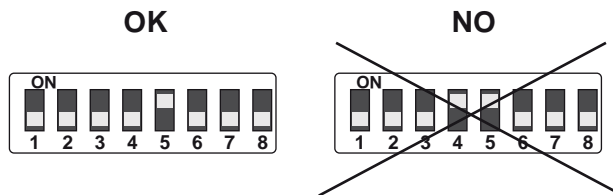

It is recommended to move a single micro switch for each operating speed . The displacement of two or more micro switches may generate incorrect power supply voltages with malfunction or damage to the unit .

3.4 Operation limits

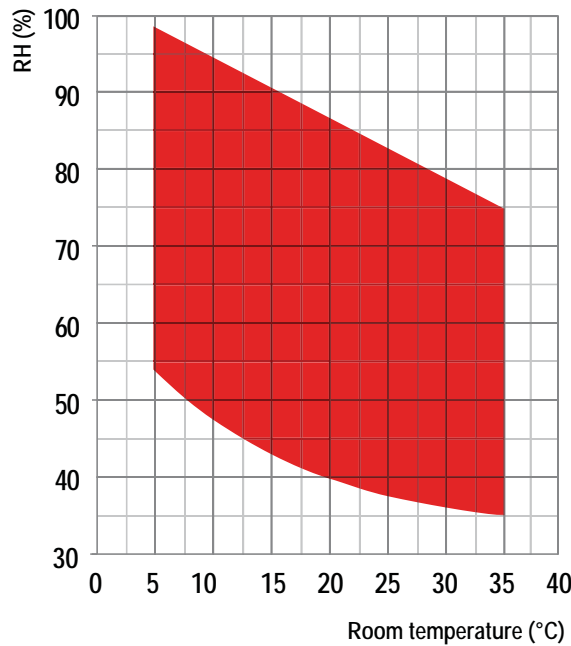

The units **MUST** be used within the operation limit indicated in the diagrams (see above). the warranty will be invalidated if the units are used in ambient conditions outside the limits reported. If there is the necessity to operate in different conditions, please contact our technical office.



Units are designed to operates with hot water coil supply temperature variables from 55°C to 80°C



The units are designed to operate within false ceiling and/or heated technical room. The units are **NOT** suitable for outdoor installations and / or technical room w/o heat (attics, rooms communicating with the outside) as it may form condensation on the walls and inside the unit cabinet causing damages.



The units are designed to work in clean ambients and with the standard characteristics of the ambient air. It's suitable not to install the unit in swimming pools or ambient with polluted and/or aggressive air. Contact the Company in case of necessity.

3.5 Sound data

Sound data										
Modd.	Octave band (Hz)								Lw (A)	Lp (A)
	63	125	250	500	1K	2K	4K	8K	dB(A)	dB(A)
	dB(A)	dB(A)	dB(A)	dB(A)	dB(A)	dB(A)	dB(A)	dB(A)		
75	72,1	63,3	57,2	55,7	54,6	49,2	45,8	36,7	59	45
100	74,1	65,3	59,2	57,7	56,6	51,2	47,8	38,7	61	47
150	80,1	71,3	65,2	63,7	62,6	57,2	53,8	44,7	67	52
200	82,1	73,3	67,2	65,7	64,6	59,2	55,8	46,7	69	54

Lw: Sound power level according to ISO 9614 fan with available static pressure 50 Pa.

Lp: Sound pressure level measured at 1 mt from the unit in free field conditions direction factor Q=2 according to ISO 9614 fan with available static pressure 50 Pa.

3.6 Safety devices

3.6.1 High pressure switch

The high pressure switch stops the unit when the discharge compressor pressure is higher than the set value. The restart is automatic, done when the pressure is under the level set in the differential value.

3.6.2 Defrost sensor

It's a device which signals to the electronic control, the necessity to make the defrost cycle. Once the defrost cycle is activated, the defrost sensor also determines termination.

3.6.3 Defrosting

The frost on the coil, obstructs the air flow, reduces the available exchange area and consequently the unit performances and can seriously damage the system. All the units are supplied, standard, with a control which defrost automatically the heat exchanger if necessary. This control provides a temperature probe (defrost thermostat) on the unit evaporator. When the defrost cycle is required, the microprocessor control (according to set parameters), switches the compressor off, while the fan remains in operation. At the end of the defrost cycle, there is a timer delay to allow condensate water to clear from the coil.

4. INSTALLATION

4.1 General safety guidelines and use of symbols



Before undertaking any task the operator must be fully trained in the operation of the machines to be used and their controls. They must also have read and be fully conversant with all operating instructions.



All maintenance must be performed by TRAINED personnel and be in accordance with all national and local regulations.



The installation and maintenance of the unit must comply with the local regulations in force at the time of the installation.



Avoid contact and do not insert any objects into moving parts.

4.2 Health and safety Considerations



The workplace must be kept clean, tidy and free from objects that may prevent free movement. Appropriate lighting of the work place shall be provided to allow the operator to perform the required operations safely. Poor or too strong lighting can cause risks.



Ensure that work places are always adequately ventilated and that respirators are working, in good condition and comply fully with the requirements of the current regulations.

4.3 Personal protective equipment



When operating and maintaining the unit, use the following personal protective equipment listed below as required by law.



Protective footwear.



Eye protection.



Protective gloves.



Respiratory protection.



Hearing protection.

4.4 Inspection

When installing or servicing the unit, it is necessary to strictly follow the rules reported on this manual, to conform to all the specifications of the labels on the unit, and to take any possible precautions of the case. Not observing the rules reported on this manual can create dangerous situations. After receiving the unit, immediately check its integrity. The unit left the factory in perfect conditions; any eventual damage must be questioned to the carrier and recorded on the Delivery Note before it is signed. The company must be informed, within 8 days, of the extent of the damage. The Customer should prepare a written statement of any severe damage.

Before accepting the unit check:

- The unit did not suffer any damage during transport;
- The delivered goods are conforming to what shown in the delivery note.

In Case of Damage

- List the damage on the delivery note
- Inform the Company of the extent of the damage within 8 days of receipt of the goods. After this time any claim will not be considered.
- A full written report is required for cases of severe damage.

4.5 Storage

Units should be stored under cover and ideally, should remain in their packaging. The tools that are supplied for opening the electric box should be formally transferred to the person responsible for the plant.

4.5.1 Shipment

The shipment must be carried out by authorised carriers and the characteristics of the vehicle used must be such as to avoid damaging the machinery transported/to be transported, neither during loading and unloading nor during transport. If the roads to be driven are irregular, the vehicle must be fitted with special suspensions or internal walls in order not to damage the unit during the shipment.



The maximum ambient temperature for storage/shipment is +45°C and the minimum is -20°C,

4.6 Unpacking



Packaging could be dangerous for the operators.

It is advisable to leave packaged units during handling and remove it before the installation. The packaging must be removed carefully to prevent any possible damage to the machine. The materials constituting the packaging may be different in nature (wood, cardboard, nylon, etc.).



The packaging materials should be separated and sent for disposal or possible recycling to specialist waste companies.

4.7 Lifting and handling

When unloading the unit, it is highly recommended to avoid any sudden move in order to protect refrigerant circuit, copper tubes or any other unit component. Units can be lifted by using a forklift or, in alternative, using belts, being sure that the method of lifting does not damage the lateral panels and the cover. It is important to keep the unit horizontal at all time to avoid damages to the internal components.

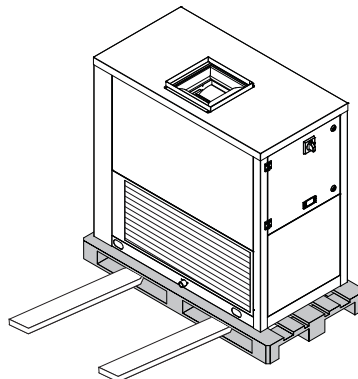

4.8 Location and minimum technical clearances



The unit has to be installed such that maintenance and repair is possible. The warranty does not cover costs for the provision of lifting apparatus, platforms or other lifting systems required to perform repairs during warranty period.



The installation site should be chosen in accordance with EN 378-1 and 378-3 standards. When choosing the installation site, all risks caused by accidental refrigerant leakage should be taken into consideration.

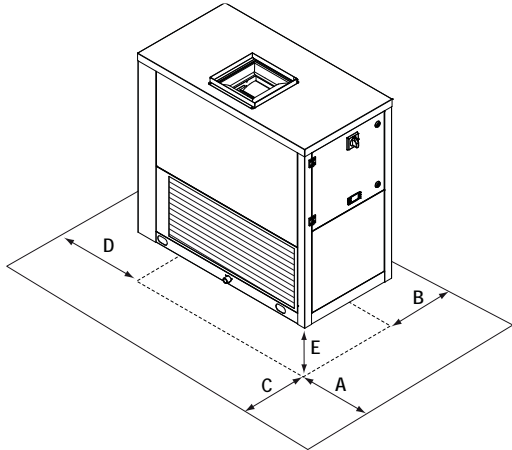

Mod.	A	B	C	D	E
75	400	300	500	300	200
100	400	300	500	300	200
150	500	300	500	300	200
200	500	300	500	300	200

4.9 Condensate draining connections

Condensate drainage should be done using a flexible rubber pipe (approximately 1 meter long). On the condensate discharge pipe it must be installed a syphon with a minimum height equal to the suction pressure of the fan.

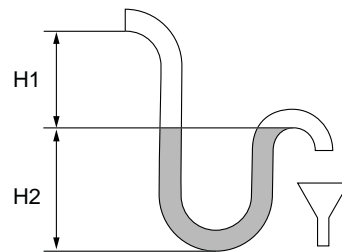
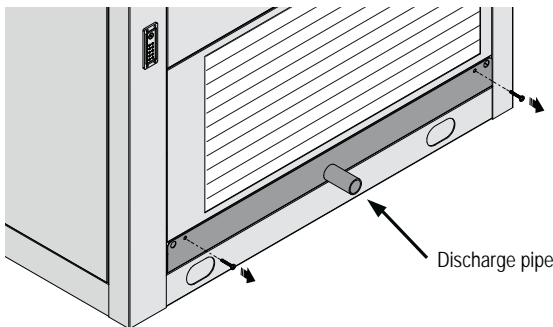

$H1 = 20 \text{ mm}$
 $H2 = \Delta P / 2 + 20 \text{ mm}$
 $\Delta P =$ pressure difference inside the unit in mm water column
 $10 \text{ Pa} \approx 1 \text{ mm water column}$



The syphon must be filled with water before being put into operation



The condensate drain line should have a water trap which may have minimum flying height equal to the suction of the fan, in any case never less than 35 mm.

4.9.1 How to remove the drip tray

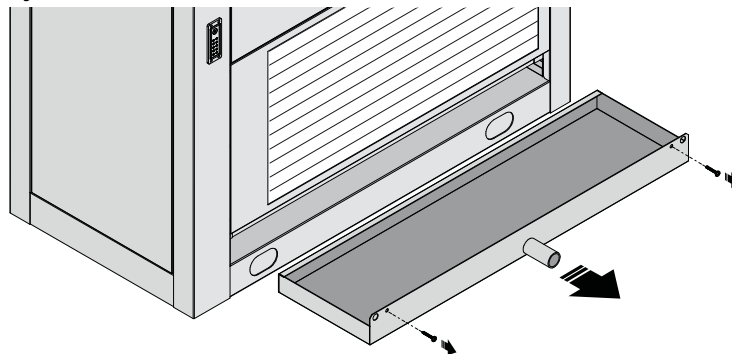

4.10 How to remove filters

4.10.1 How to remove filters in standard configuration

Remove the fixing metallic frame and slide off the air filter as shown below.

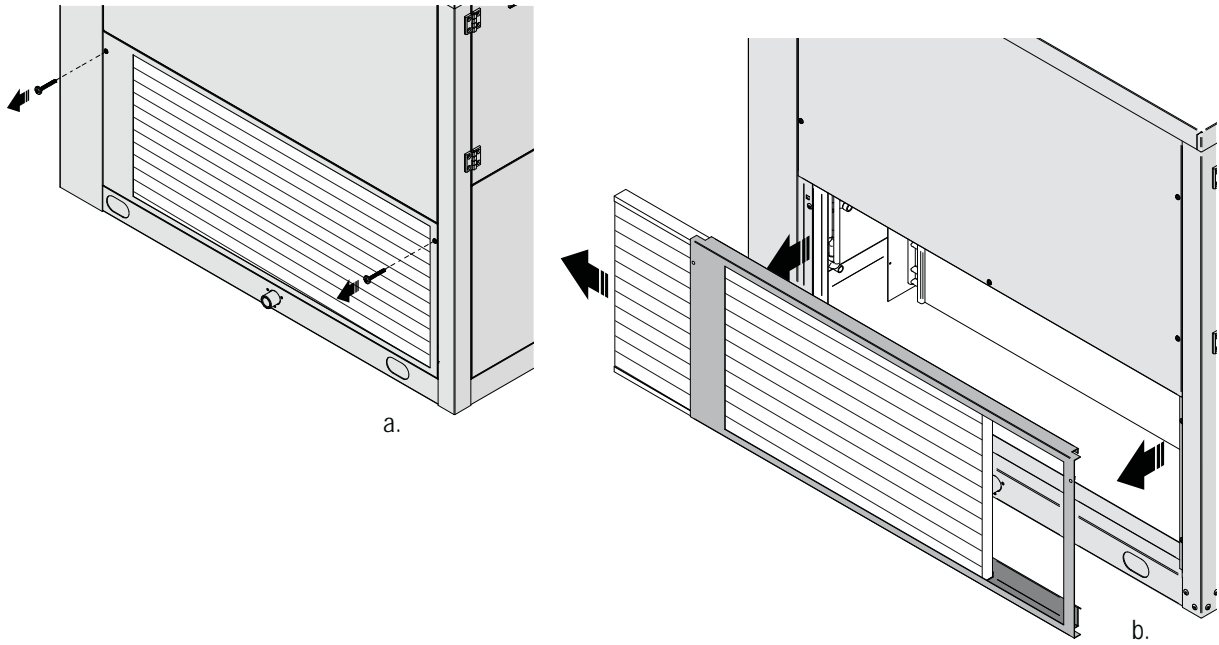

4.10.2 How to remove filter with accessory FARC

In case the unit is supplied with FARC (frame for ducted installation) slide off the air filter as shown below.

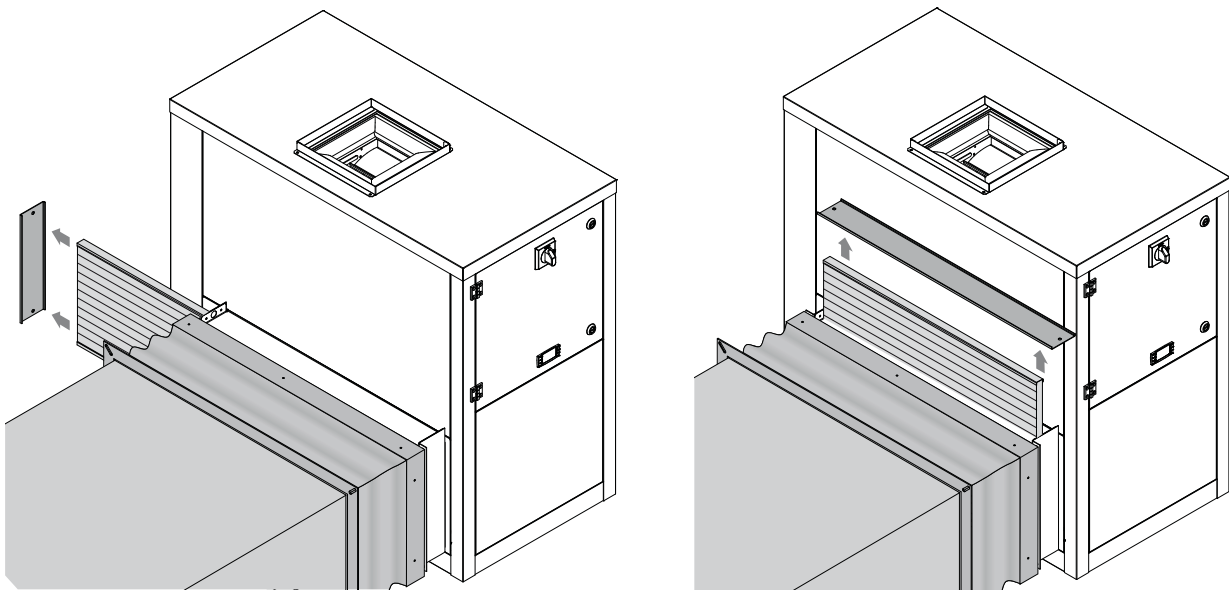

4.11 Installation of built-in room electronic sensor (RGDD)

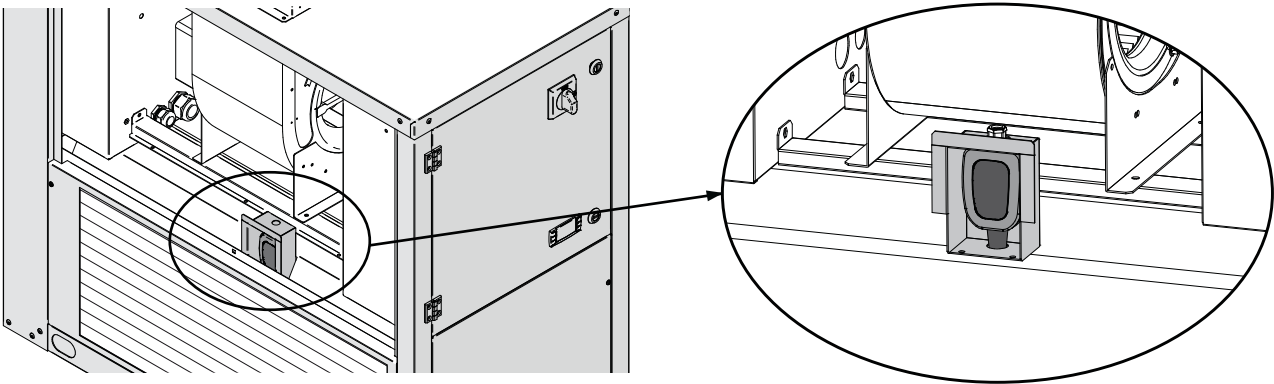

4.12 Serial interface card RS485 (INSE)

Supervision system interface serial board (MODBUS RS485 available only) The installation of the card will allow the unit to be plugged in and connected to a system with MODBUS protocol. This system allows you to remotely monitor all parameters of the unit and change their values. The serial interface board is normally fitted at the factory, where it is provided separately is necessary to respect the polarity of the wiring as shown in the diagram. Any reversal of polarity will result in the non-functioning unit.

The supervision connectivity cable must be telephone one type 2x0, 25 mm².

The unit is configured at the factory with serial address 1. In case of using the MODBUS system, you can request the list of variables by contacting the assistance.

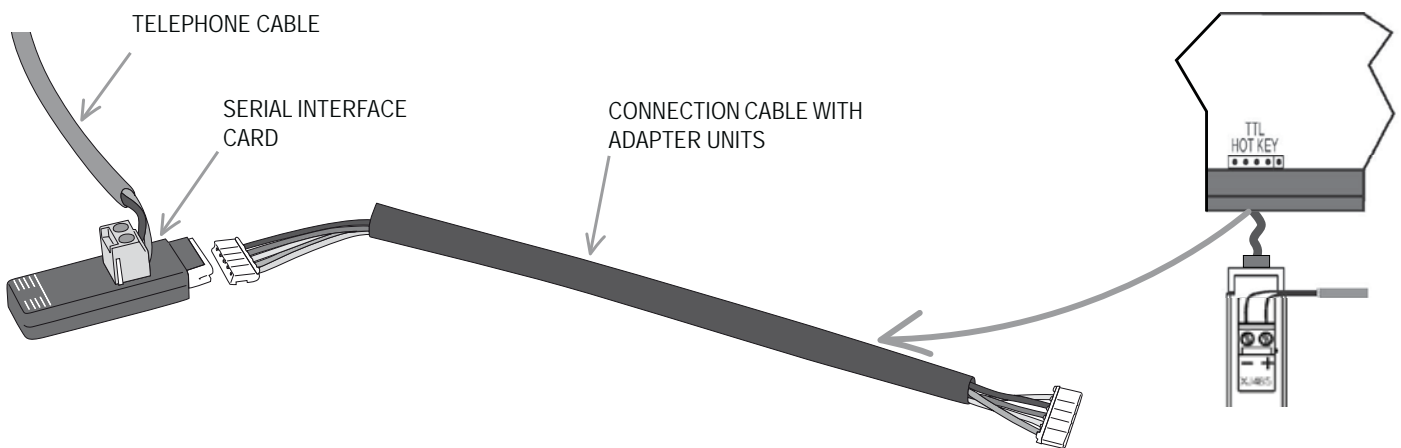

4.13 Connecting the unit to air duct channels

Units can be connected to air ducts channels either form the return and supply side.

4.13.1 Supply duct connection



In order to enable the proper functioning of the unit is important to ensure a constant air flow to the unit close to the nominal stated value. The maximum deviation allowed is 10%.



In order to limit the noise, it is necessary that the air speed inside ducts would never exceed 4 m / sec. With crossing high speed, it greatly reduces the dehumidification capacity of the unit and increases the risk of dragging of water condensation in the air ducts with a potential damage to the furniture and / or flooring.



It is always recommended to use a flexible connection between the unit and air distribution system (duct channel) in order to reduce the transmission of vibrations

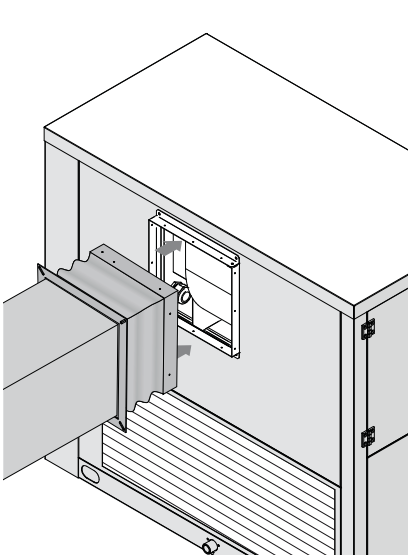

ASLE
Left hand side Supply

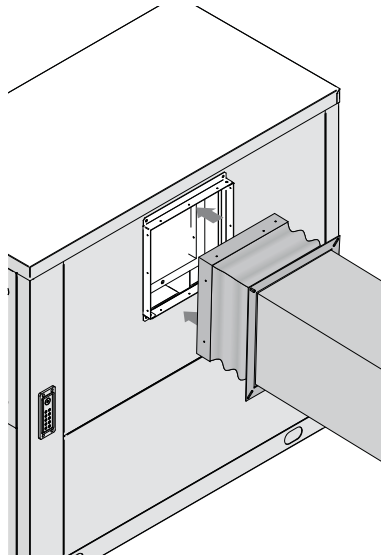

ASRI
Right hand side Supply

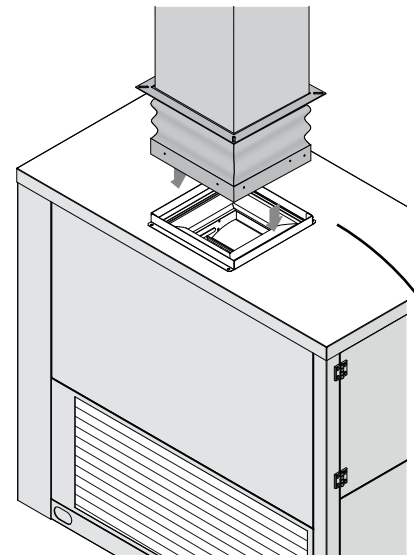

ASVE
Vertical Supply (standard)

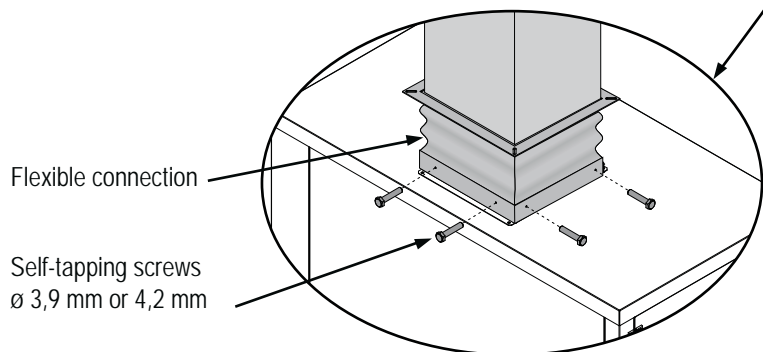

Air duct fixing at the supply and return ports

4.13.2 Return duct connection with FARC option

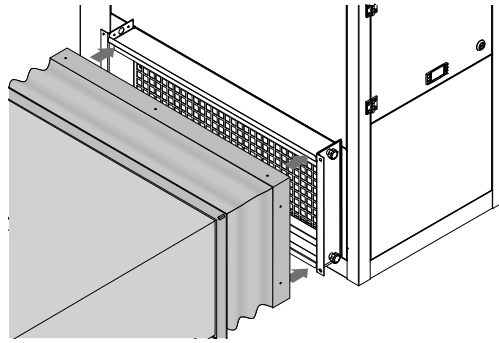

In case of return duct installation it is necessary the use of accessory FARC, a metallic frame that allow the slide off the air filter laterally.

4.14 Fan positioning

In all units the supply fan can be oriented in 3 different directions. The operation has to be carried out exclusively in the factory. Standard configuration is with vertical air discharge.

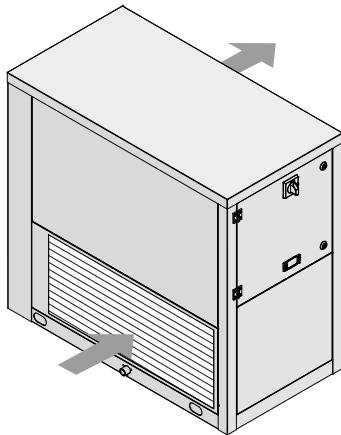

ASRI
Right hand side Supply

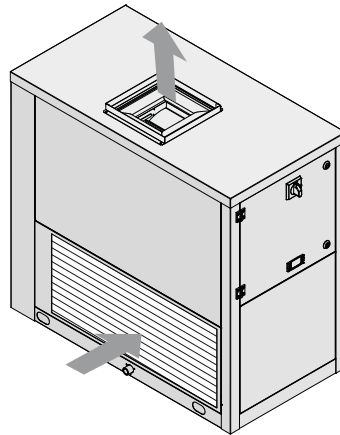

ASVE
Vertical Supply (standard)

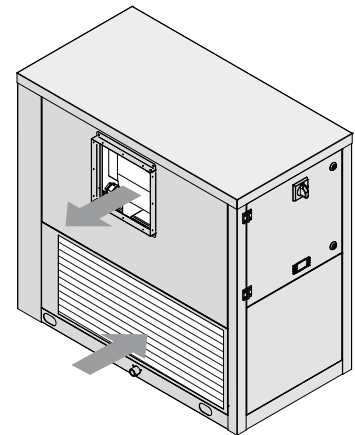

ASLE
Left hand side Supply

4.15 Remote mechanical hygostat installation (HYGR)

The remote mechanical humidistat (HYGR) must be installed in the room to be treated at 1.2 - 1.5 m above the floor (wall mounted) in a position such as not receive external irradiations or air drafts. It should be noted that the values in the numbered scale identify the desired room relative humidity (%).

The humidistat is supplied separately. For connection please refer to the wiring diagram supplied along with the unit.

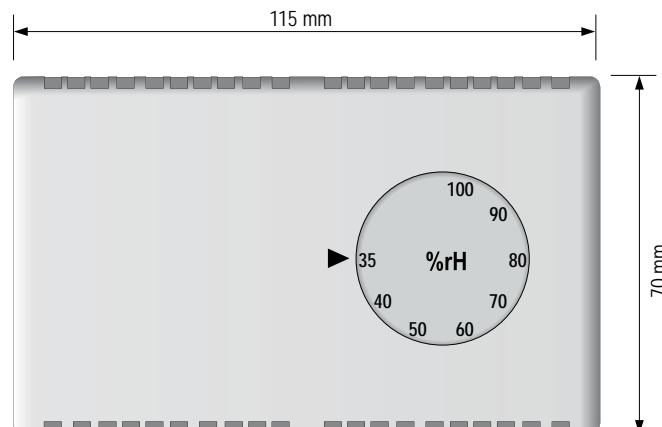



If humidistat or thermohygrostate is used, make sure that it can guarantee a correct reading of humidity and temperature in the environment and that this reading is similar to that in suction side. Under no circumstances can the sensor be placed in an ambient different from the unit's suction, nor can it be installed in areas where air flow is hampered.



To ensure a proper reading of temperature and humidity make sure that the device is not near hot or cold air flows or behind curtains or other obstacles.

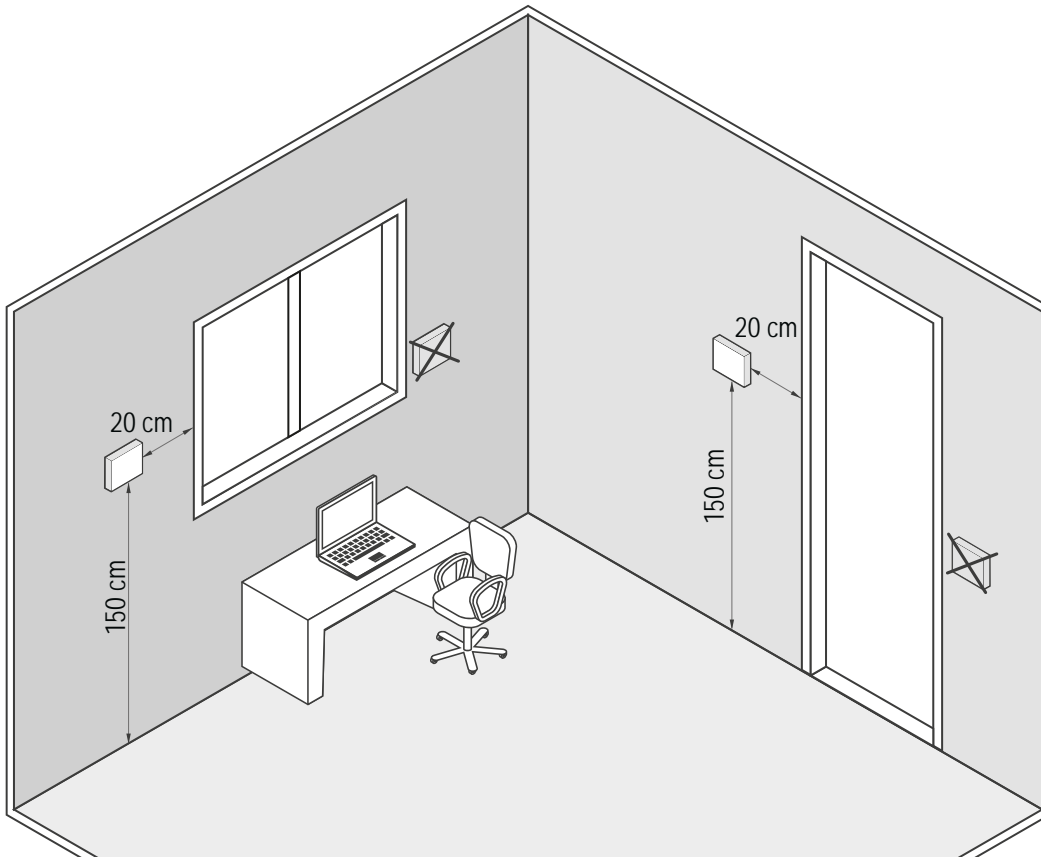

4.16 Electric connections: preliminary safety information

The electric panel is located inside the unit at the top of the technical compartment where the various components of the refrigerant circuit are also to be found. To access the electrical board, remove the front panel of the unit:



Power connections must be made in accordance to the wiring diagram enclosed with the unit and in accordance to the norms in force.



Make sure the power supply upstream of the unit is (blocked with a switch). Check that the main switch handle is padlocked and it is applied on the handle a visible sign of warning not to operate.



It must be verified that electric supply is corresponding to the unit electric nominal data (tension, phases, frequency) reported on the label in the front panel of the unit.



Power cable and line protection must be sized according to the specification reported on the form of the wiring diagram enclosed with the unit.



The cable section must be commensurate with the calibration of the system-side protection and must take into account all the factors that may influence (temperature, type of insulation, length, etc.).



Power supply must respect the reported tolerances and limits: If those tolerances should not be respected, the warranty will be invalidated.



Flow switches must be connected following the indication reported in the wiring diagram. Never bridge flow switches connections in the terminal board. Guarantee will be invalidated if connections are altered or not properly made.



Make all connections to ground provided by law and legislation.



Before any service operation on the unit, be sure that the electric supply is disconnected.



The power line and the unit external safety devices must be sized in order to ensure the correct voltage at the maximum operating conditions of the unit reported in the wiring diagram of the unit.



FROST PROTECTION

If opened, the main switch cuts the power off to any electric heater and antifreeze device supplied with the unit, including the compressor crankcase heaters. The main switch should only be disconnected for cleaning, maintenance or unit repair.

4.17 Electrical data



The electrical data reported below refer to the standard unit without accessories. In all other cases refer to the data reported in the attached electrical wiring diagrams.



The line voltage fluctuations can not be more than $\pm 10\%$ of the nominal value, while the voltage unbalance between one phase and another can not exceed 1%, according to EN60204. If those tolerances should not be respected, please contact our Company.

Model		75	100	150	200
Power supply	V/~/Hz	230/1/50	230/1/50	230/1/50	230/1/50
Control board	V/~/Hz	24 V	24 V	24 V	24 V
Auxiliary circuit	V/~/Hz	230/1/50	230/1/50	230/1/50	230/1/50
Fans power supply	V/~/Hz	230/1/50	230/1/50	230/1/50	230/1/50
Line section	mm ²	4	4	6	6
PE section	mm ²	4	4	6	6



Electric data may change for updating without notice. It is therefore necessary to refer always to the wiring diagram present in the units.

4.18 How to connect the power supply

For powering the unit remove the front panel; use the appropriate cable gland present in the side panel and connect the power cord to the terminal block in the cabinet. After connecting all cable carefully close the front panel.

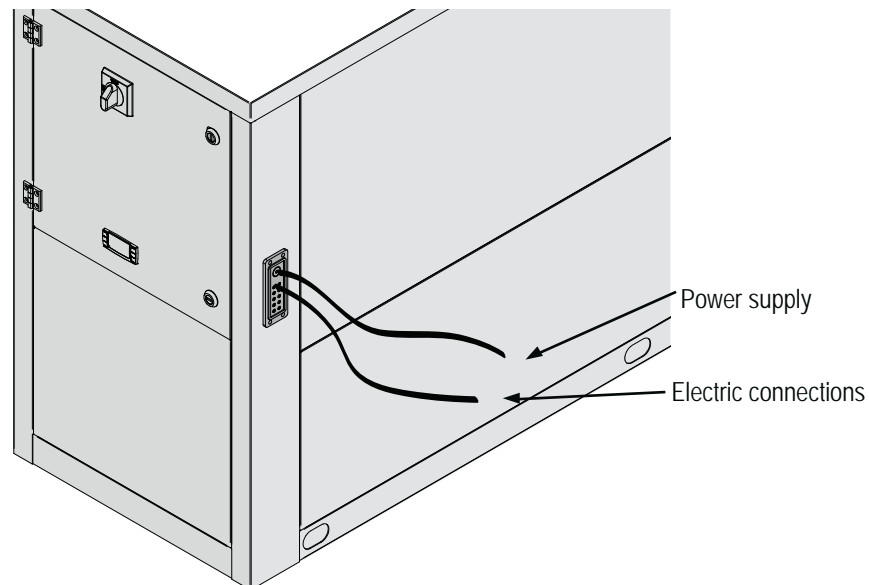

4.19 Electric connections



The numbering of the terminals may change without notice. For their connection is mandatory to refer to the wiring diagram supplied along with the unit.

4.19.1 Remote wiring connections

All terminals referred to in the explanations below will be found on the terminal board inside the electrical box. All electric connections mentioned below have to be made by the installer, on site.



REMOTE ON / OFF

To switch the unit on or off from remote control.
 Contacts are voltage free.
 Units are supplied standard with bridged terminals.
 Contact closed, unit ON,
 Contact open, unit OFF.

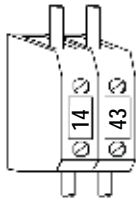

ROOM HYGROSTAT (UA)

(Only if remote mechanical hygostat (HYGR) is used)
 Contact UA open: unit off.
 Contact UA closed: unit in operation.

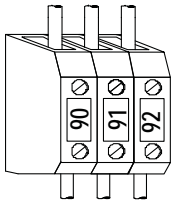

REMOTE GENERAL ALARM

For remote display of a general alarm, connect the visual or audible device between terminals 90-91-92.
 Contacts 90/91 NC (Normally closed)
 Contacts 91/92 NO (Normally opened)

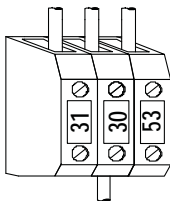

FAN SPEED

The electric motors are directly connected to the fan; they are all at 3 speeds, with integrated thermal protection.
 Contact 31: Minimum speed
 Contact 30: Medium speed
 Contact 53: Maximum speed

4.20 Refrigerant circuit layout

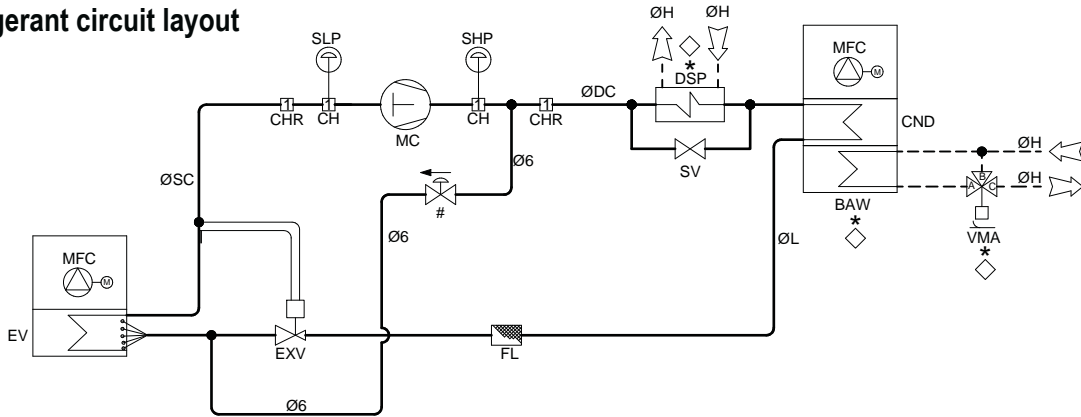

CH	Charging plug	MC	Compressor
CHR	Charging plug	MFC	Centrifugal fan
CND	Condenser	SHP	High pressure pressostat
EV	Evaporator	SLP	Low-high pressure switch
EXV	Thermostatic valve	YBP	Hot gas by-pass solenoid valve
FL	Liquid line filter	YMI	Solenoid valve for internal condenser
IV	Moisture indicator sight glass	*	Not present



The cooling circuit principle diagram is purely indicative.

5. UNIT START UP

5.1 Preliminary checks

Before starting the unit the checks detailed in this manual of the electric supply and connections, the hydraulic system and the refrigerant circuit, should be performed.



Start-up operations must be performed in accordance with the instructions detailed in the previous paragraphs.

5.1.1 Before start-up



Damage can occur during shipment or installation. It is recommended that a detailed check is made, before the installation of the unit, for possible refrigerant leakages caused by breakage of capillaries, pressure switch connections, tampering of the refrigerant pipework, vibration during transport or general abuse suffered by the unit.

- Verify that the unit is installed in a workmanlike manner and in accordance with the guidelines in this manual.
- Check that all power cables are properly connected and all terminals are correctly fixed.
- The operating voltage the one shown on the unit labels.
- Check that the unit is connected to the system earth.
- Check that there is no refrigerant leakage.
- Check for oil stains, sign of a possible leak.
- Check that the refrigerant circuit shows the correct standing pressure on the pressure gauges (if present) otherwise use external ones.
- Check that the Shrader port caps are the correct type and are tightly closed.
- Check that crankcase heaters are powered correctly (if present).
- Check that all water connections are properly installed and all indications on unit labels are observed.
- The system must be flushed, filled and vented in order to eliminate any air.
- Check that the water temperatures are within the operation limits reported in the manual.
- Before start up check that all panels are replaced in the proper position and locked with fastening screws.

5.2 Description of the control panel



5.2.1 Display icons

The instrument display is divided into three zones:

Left Zone: the display shows the icons,

Top right zone: the display shows room temperature.

Bottom right zone: the display shows room humidity.

Icon	Meaning	Icon	Meaning
	Not used.		Not used.
	Compressors 1 and 2.	LP	Not used.
	Dehumidification.	HP	High Pressure.
	Not used.		General Alarm.
	Unit fan.	Vset	Not used.
	On if the unit is turned on.	menu	Function menu active.
	Electric heater or water valve activated.	Flow!	Not used.

5.2.2 Key function



M Press and release: makes it possible to enter the functions menu.



SET Press and release in the main display:

makes it possible to display the set points;

Humidity set, in the bottom line will appear the label **SETI**.

Temperature set, in the bottom line will appear the label **SETH**.

Press for 3 seconds and release in the main display:

makes it possible to modify the set points;



In standard mode, with electronic sensor installed, allows the display of the following icons:

1 click: The bottom line displays **Tamb**: room temperature.

2 clicks: The bottom line displays **rH**: room humidity.

In standard mode with mechanical thermostat/hygrostat, allows the display of the following icons:

the top line displays the label **TOn** (room temperature request) or **TOff** (room temperature in set).

the bottom line displays the label **UOn** (room humidity request) or **UOff** (room humidity in set).

In programming mode it allows the user to scroll through parameter codes or to change values.



In standard mode allows the display of the different temperatures in opposite way of the above arrow.

In programming mode allows to scroll through the parameter codes or increases the values



If pressed down for 5 seconds, it makes it possible to switch the unit on or off.

5.3 Remote control panel



5.3.1 Display icons

The instrument display is divided into three zones:

Left Zone: the display shows the icons,

Top right zone: the display shows ambient temperature.

Bottom right zone: the display shows ambient humidity.

Icon	Meaning	Icon	Meaning
	Not used.		Not used.
	Compressors 1 and 2.	LP	Not used.
	Dehumidification.	HP	High Pressure.
	Not used.		General Alarm.
	Unit fan.	Vset	Not used.
	On if the unit is turned on.	menu	Function menu active.
	Electric heater or water valve activated.	Flow!	Not used.

5.3.2 Key functions



M Press and release: makes it possible to enter the functions menu



SET Press and release in the main display:

makes it possible to display the set points;

Humidity set, in the bottom line will appear the label **SETI**.

Temperature set, in the bottom line will appear the label **SETH**.

Press for 3 seconds and release in the main display:

makes it possible to modify the set points;

In standard mode, with electronic sensor installed, allows the display of the following icons:

1 click: The bottom line displays **Tamb**: room temperature.

2 clicks: The bottom line displays **rH**: room humidity.



In standard mode with mechanical thermostat/hygrostat, allows the display of the following icons:
the top line displays the label **TOn** (room temperature request) or **TOff** (room temperature in set).
the bottom line displays the label **UOn** (room humidity request) or **UOff** (room humidity in set).

In programming mode it allows the user to scroll through parameter codes or to change values.



In standard mode allows the display of the different temperatures in opposite way of the above arrow.

In programming mode allows to scroll through the parameter codes or increases the values



If pressed down for 5 seconds, it makes it possible to switch the unit on or off.

6. USE

6.1 Switch the unit on

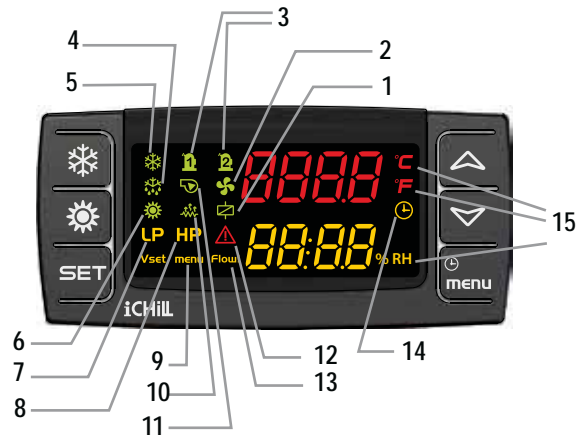

Legend

1	Not used.	9	Icon ON: function menu active.
2	Icon ON: if fans are running.	10	Icon ON: Electric heater or water valve activated.
3	Icon ON: if the compressor is turned on; Icon blinking: if the compressor is the in start delay.	11	Not used.
4	Icon ON: Dehumidification cycle activated.	12	Icon blinking on alarm.
5	Not used.	13	Not used.
6	Icon ON: the unit is on.	14	Counter between two defrost cycles.
7	Not used.	15	Icon ON: the display shows the room temperature or humidity.
8	Icon blinking: high pressure alarm is active.		

In order to power the unit, turn the main switch to the ON position.

a. In case of electronic sensor the display shows room humidity (in the bottom line).

b. In case of remote mechanical thermostat/hygrostat the display shows tOFF/UOFF (temperature/humidity off, unit in set) or tOn/UOn (temperature/humidity on, unit running).



Push 5 seconds the key to start the unit.

6.1.2 Display during operation

Defrost

Unit equipped with electronic sensor



Defrost

Unit equipped with mechanical thermostat/hygrostat



Unit in drip time after defrost

Unit equipped with electronic sensor



Unit in drip time after defrost

Unit equipped with mechanical thermostat/hygrostat



6.2 Stop

to stop the unit press the key  for 5 seconds. The unit goes into stand-by mode.

6.3 Stand-by

When the unit is switched off from keyboard or remote control panel, it goes into stand-by mode. In this mode the microprocessor control displays the sensor readings and is also able to manage alarm situations. The only visible label on the display is the humidity (in case of unit equipped with electronic sensor), or OFF (in case of unit equipped with mechanical thermostat/hygrostat). In case the unit is switch off from the remote ON/OFF contact, the display shows OFF.

Display in stand-by mode.



Display in OFF from remote contact.



6.4 How to change the set points







When modifying or varying the machine's operating parameters, make sure that you do not create situations that conflict with the other set parameters.

Select the required set point pressing the  key. The label appears at the bottom of the display:

SEtI Room humidity set point;

SEtH Room temperature set point.

To set the required set-points press again the  for 3 seconds. The current value flashes at the top and can be modified using the  ,  keys we can modify the parameter. Then press the  key to memorise the parameter and exit.



All set points are intended as room conditions.

6.4.1 Adjustable parameters

The adjustable set points that can be modified by the end user are:

Label	Function	Adjustment limit	Default value
SEt I	Room humidity set point	40÷90%	50%
SEt H	Room temperature set point	---	---
PAS	Password	(Contact the Company)	



The units are supplied with a very sophisticated control system with many other parameters that are not adjustable by the end user; these parameters are protected by a manufacturer password.

6.5 Acoustic signal silencing

Pressing and releasing one of the keys; the buzzer is switched off, even if the alarm condition remains in place.



6.6 Display during alarm





In case of alarm the display shows:

-  + alarm code in the bottom line, (the bottom line of the display shows the alarm code in alternatively to the standard label).

6.7 Alarm reset

Press the  key (the menu **AlrM** appears at the bottom right of the display). Press the  key to display the alarm event.

In case of multiple alarms, use the ,  keys to scroll the list of the active alarms.
There are two types of alarms:

Reset alarms:

RST label appears on the upper part of the display. In this case press the  key to reset.

Non reset alarms:

The **nO** label appears on the upper part of the display. In this case the alarm is permanent; contact the Company.

7. MAINTENANCE OF THE UNIT

7.1 General warnings



Starting from 01/01/2016 the new European Regulation 517_2014, "Obligations concerning the containment, use, recovery and destruction of fluorinated greenhouse gases used in stationary refrigeration, air conditioning and heat pumps", became effective. This unit is subject to the following regulatory obligations, which have to be fulfilled by all owners, operators and technical staff:

- (a) Keeping the equipment records
- (b) Correct installation, maintenance and repair of equipment
- (c) Leakage control
- (d) Refrigerant recovery and disposal management
- (e) Presentation to the Ministry of the Environment of the annual declaration concerning the atmospheric emissions of fluorinated greenhouse gases.

Maintenance can:

- Keep the equipment operating efficiently
- Prevent failures
- Increase the equipment life



It is advisable to maintain a record book for the unit which details all operations performed on the unit as this will facilitate troubleshooting.



Maintenance must be performed in compliance with all requirements of the previous paragraphs.



Use personal protective equipment required by regulations as compressor casings and discharge pipes are at high temperatures. Coil fins are sharp and present a cutting hazard.



If the unit is not to be used during the winter period, the water contained in the pipes may freeze and cause serious damage. In this event, fully drain the water from the pipes, checking that all parts of the circuit are empty including any internal or external traps and siphons.



If it is necessary to replace a component of the machine, both for ordinary and extraordinary maintenance, this component must have the same or higher characteristics than those present. The same or higher performances or thicknesses are meant for the characteristics, which do not compromise the safety, the use, the handling, the storage, the pressures and the temperatures of use of the machine provided by the manufacturer.



The taps in the machine must always be in open position before starting. If it is necessary to disconnect the refrigeration circuit by closing the taps, it is necessary to take precautions to prevent the unit from starting up, even accidentally, and to indicate that the taps have been properly closed with special signs, both on the tap and in the electrical panel. In any case, the taps must remain closed as less as possible.

7.2 Drive access

Access to the unit once installed, should only be possible to authorized operators and technicians. The owner of the equipment is the company legal representative, entity or person owns the property where the machine is installed. They are fully responsible for all safety rules given in this manual and regulations.

7.3 Scheduled maintenance

The owner must make sure that the unit is periodically inspected, also on-site, adequately maintained, according to the type, size, age and use of the system, and to the indications contained in the Manual.

Servicing during the unit's operating lifetime and, in particular, scheduled leak detection, on-site inspections and check-ups of safety equipment, must be carried out as provided by local laws and regulations in force.



If leak detection instruments are installed on the system, they must be inspected at least once a year, to make sure that they work properly.

During its operating life, the unit shall be inspected and verified in accordance with applicable local laws and regulations. In particular, when there are no stricter specifications, the indications given in the following table (see EN 378-4, Annex D) must be followed, with reference to the situations described.

CASE	Visual Inspection	Pressure Test	Search for leaks
A	X	X	X
B	X	X	X
C	X		X
D	X		X

A	Inspection after an intervention with possible effects on the mechanical strength or after use change or in case the machine has not being working for more than two years. Replace all the components which are not suitable any more. Do not carry out checks at a higher pressure than the one indicated in the project.
B	Inspection after a repair, or significant adjustment of the system, or its components. The check may be limited to the interested parts, but if a leakage of refrigerant is detected, a leakage search must be carried out on the entire system.
C	Inspection after installation in a different position than the original one. Refer to point A when mechanical strength could have been affected by the change.
D	Leak search, following a well-founded suspicion of refrigerant leakage. It is recommended examined the system for leakage, either directly (use of leak detection systems) or indirectly (deduction of leakage based on analysis of operating parameters), focusing on the parts most prone to leakage (e.g. joints).



If a defect is detected that compromises the reliable operation of the unit, the unit cannot be re-started until it has been repaired.

7.4 Periodical checks and start up



The start-up operations should be performed in compliance with all requirements of the previous paragraphs.



All of the operations described in this chapter **MUST BE PERFORMED BY TRAINED PERSONNEL ONLY**. Before commencing service work on the unit ensure that the electric supply is disconnected. The top case and discharge line of compressor are usually at high temperature. Care must be taken when working in their surroundings. Aluminium coil fins are very sharp and can cause serious wounds. Care must be taken when working in their surroundings. After servicing, replace the cover panels, fixing them with locking screws.

7.4.1 Electrical system and adjustment

Action to be performed	Frequency					
	Monthly	Every 2 months	Every 6 months	Every year	Every 5 years	As necessary
Check that the unit works properly and that there are no active warnings	X					
Visually inspect the unit	X					
Check noise and vibration level of the unit				X		
Check operation of safety features and of interlocks				X		
Check the unit's performance				X		
Check the current draws of the different parts (compressors, fans, pumps, etc.)				X		
Check the supply voltage of the unit			X			
Check tightness of cables in their clamps			X			
Check the integrity of the insulating coating of power cables				X		
Check the conditions and functioning of the counters				X		
Check functioning of the microprocessor and of the display			X			
Clean the electrical and electronic components of any dust				X		
Check functioning and calibration of probes and transducers				X		

7.4.2 Condensing coils and fans

Action to be performed	Frequency					
	Monthly	Every 2 months	Every 6 months	Every year	Every 5 years	As necessary
Visually inspect the coil	X					
Clean finned coils			X			
Check the water flow and/or any leaks (if HOWA is present)	X					
Clean the metal filter on the external water line ⁽²⁾ (if present)			X			
Check noise and vibration level of the fans				X		
Check the supply voltage of the fans			X			
Check the fans' electrical connections				X		
Check functioning and calibration of the fans' speed adjustment system (if present)				X		
Check air presence in the hydraulic circuit	X					
Check color of moisture indicator on liquid line				X		
Check for freon leaks ⁽¹⁾						X



⁽¹⁾ In order to carry out operations on the refrigerant, it is necessary to observe the European Regulation 517_2014, "Obligations regarding the containment, use, recovery and destruction of fluorinated greenhouse gases used in stationary refrigeration, air conditioning and heat pump equipment".



⁽²⁾ It can be carried out with a higher frequency (also weekly) depending on the Δt .

7.4.3 Compressors

Action to be performed	Frequency					
	Monthly	Every 2 months	Every 6 months	Every year	Every 5 years	As necessary
Visually inspect compressors				X		
Check noise and vibration level of the compressors				X		
Check the supply voltage of the compressors			X			
Check the compressors' electrical connections				X		
Check oil level in the compressors using the oil fill level indicator (if present)			X			
Check that the crankcase heaters are powered and working properly (if present)				X		
Check the conditions of the compressors' power cables and their tightness in the clamps			X			



Daily and monthly works may be carried out directly by the Owner of the system. All other works must be performed by authorised and trained personnel.



Any kind of cleaning whatsoever is forbidden before disconnecting the device from power supply by turning the master switch to the OFF position. It is forbidden to touch the device while barefooted or with wet or damp body parts.



Works on the cooling line must be carried out by qualified and trained technicians, as provided by local laws and regulations in force.



Before the start-up it is necessary to carry out all the operations described in the previous tables and make the necessary checks provided by the pre-start control module (valid for the Italian market) to be requested to the service.

7.5 Refrigerant circuit repair



If the refrigerant circuit is to be emptied, all the refrigerant must be recovered using the correct equipment by suitably qualified f-gas engineers.

For leak detection, the system should be charged with oxygen free nitrogen using a gas cylinder and suitable nitrogen pressure regulator, until 15 bar pressure is reached. Any leakage is detected using a bubble leak finder.



Never use oxygen instead of oxygen free nitrogen: explosions may occur.

Site assembled refrigerant circuits must be assembled and maintained carefully, in order to prevent malfunctions.

Therefore:

- Avoid oil replenishment with products that are different from that specified and that are pre-loaded into the compressor.
- In the event of a gas leakage on machines using refrigerant R410A even if it is only a partial leak, do not top up. The entire charge must be recovered, the leak repaired and a new refrigerant charge weighed in to the circuit.
- When replacing any part of the refrigerant circuit, do not leave it exposed for more than 15 minutes.
- It is important when replacing a compressor that the task be completed within the time specified above after removing the rubber sealing caps.
- When replacing the compressor following a burn out, it is advisable to wash the cooling system with appropriate products including a filter for acid.
- When under vacuum do not switch on the compressor.

8. DECOMMISSIONING

8.1 Disconnect the unit



All decommissioning operations must be performed by authorized personnel in accordance with the national legislation in force in the country where the unit is located.

- Avoid spills or leaks into the environment.
- Before disconnecting the machine please recover:
 - the refrigerant gas;
 - Glycol mixtures in the eventual hydraulic circuit;
 - the compressor lubricating oil.

Before decommissioning the machine can be stored outdoors, providing that it has the electrical box, refrigerant circuit and hydraulic circuit intact and closed.

8.2 Disposal, recovery and recycling

The frame and components, if unusable, should be taken apart and sorted by type, especially copper and aluminum that are present in large quantities in the machine.

All materials must be recovered or disposed in accordance with national regulations.



The refrigerant circuit of the unit contains lubricant oil that binds the disposal mode of components .

8.3 RAEE Directive (only UE)



The crossed-out bin symbol on the label indicates that the product complies with regulations on waste electrical and electronic equipment.

The abandonment of the equipment in the environment or its illegal disposal is punishable by law.

This product is included in the application of Directive 2012/19/EU on the management of waste electrical and electronic equipment (WEEE).

The unit should not be treated with household waste as it is made of different materials that can be recycled at the appropriate facilities. Inform through the municipal authority about the location of the ecological platforms that can receive the product for disposal and its subsequent proper recycling.

The product is not potentially dangerous for human health and the environment, as it does not contain dangerous substances as per Directive 2011/65/EU (RoHS), but if abandoned in the environment it has a negative impact on the ecosystem.

Read the instructions carefully before using the unit for the first time. It is recommended not to use the product for any purpose other than that for which it was designed, as there is a risk of electric shock if used improperly.

9. DIAGNOSIS AND TROUBLESHOOTING

9.1 Fault finding

All units are checked and tested at the factory before shipment, however, during operation an anomaly or failure can occur.



BE SURE TO RESET AN ALARM ONLY AFTER YOU HAVE REMOVED THE CAUSE OF THE FAULT; REPEATED RESET MAY RESULT IN IRREVOCABLE DAMAGE TO THE UNIT.

Code	Alarm description	Electronic sensor	mechanical thermostat/hygrostat	Cause	Solution
AhiP	High pressure	Yes	Yes	Too low airflow or high room temperature.	Check the filters, if necessary replace them. In P versions, check the pressure drop of the ducts.
AloP	Low pressure	Yes	Yes	Refrigerant charge leakage.	Contact the Company
APBa/ APBi	Room temperature probe sensor alarm PBa	Yes	No	Replace faulty sensor	Contact the Company
APBu	Room humidity probe sensor alarm P Bu	Yes	No		
Atdf	Defrost time too long.	Yes	Yes	Warning	(Reporting only)
Atlo	Low room temperature.	Yes	No	Replace faulty sensor	Contact the Company
Athi	High room temperature.	Yes	No	Replace faulty sensor	Contact the Company
Atr	Electrical heater thermal alarm (if present)	Yes	Yes	Too low airflow	Check the filters, if necessary replace them. In ducted versions, check the pressure drop of the ducts.

10. Dimensional drawings

Dimensional drawings DC 75 - 100

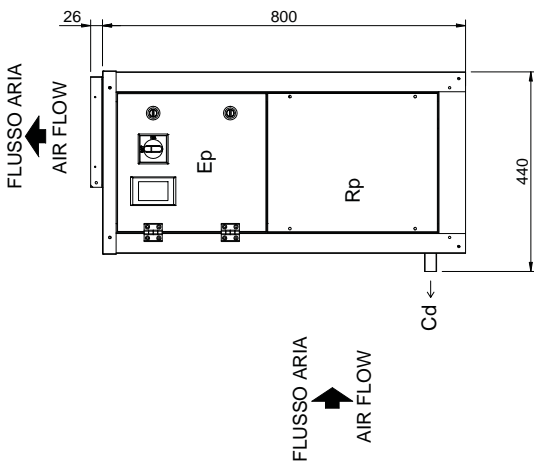
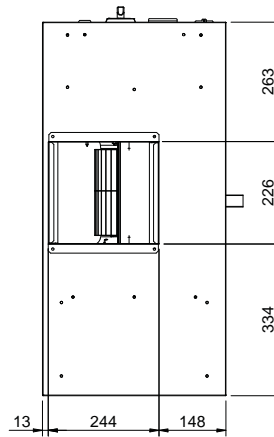
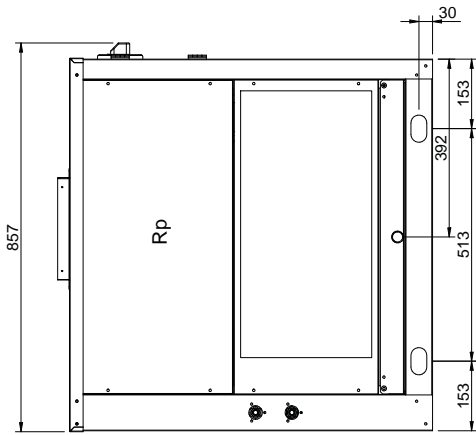
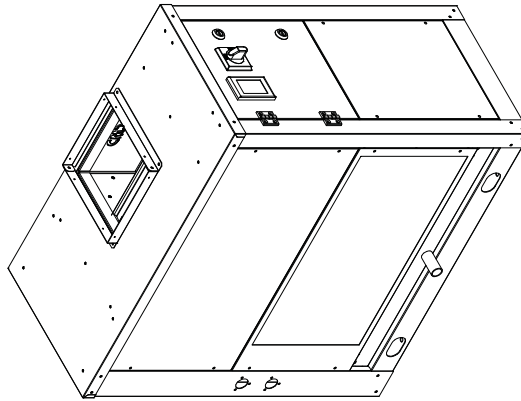
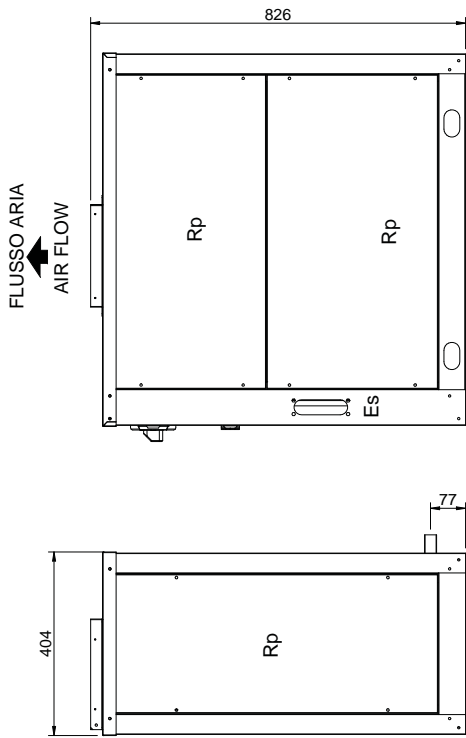

Kg	
DC 75	DC 100
Tot	85
	90

Rp	REMOVABLE PANEL
Ep	ELECTRICAL PANEL
Es	POWER SUPPLY DRAIN INLET
Cd Ø 3/4"	CONDENSATE DRAIN

Dimensional drawings DC 150 - 200

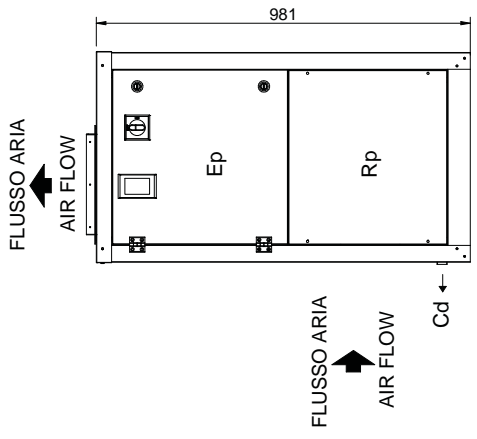
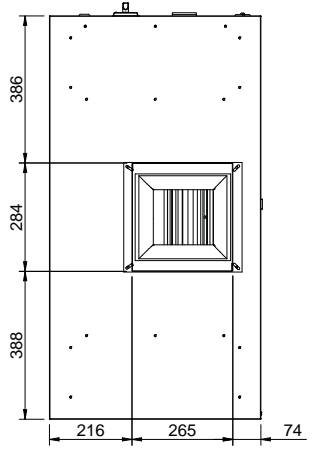
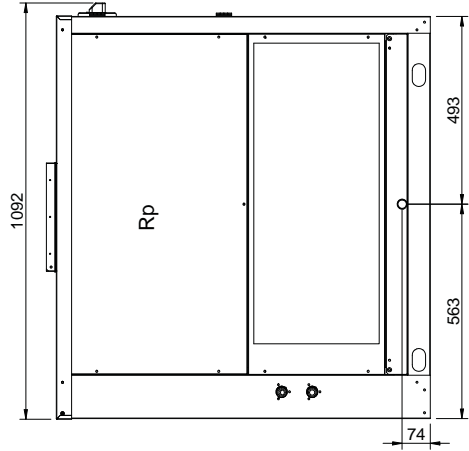
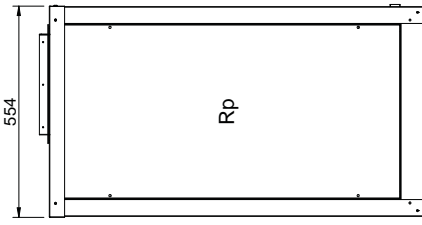
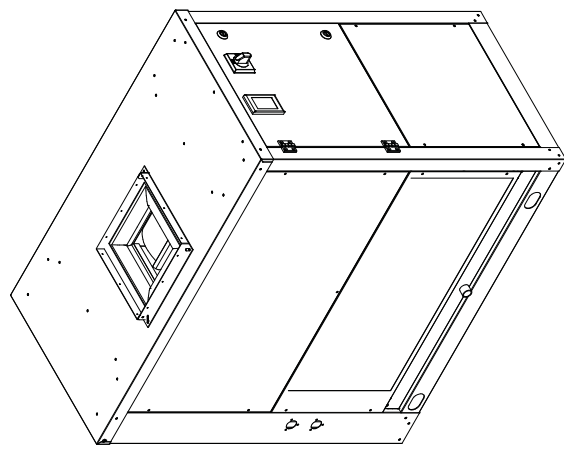
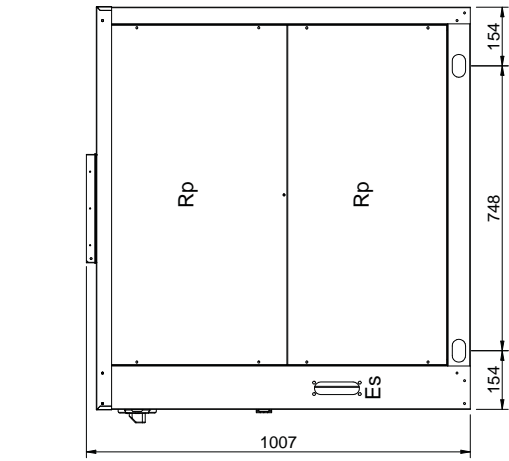

Kg	
DC 150	130
DC 200	135
Tot	

Rp	REMOVABLE PANEL
Ep	ELECTRICAL PANEL
Es	POWER SUPPLY DRAIN INLET
Cd Ø 3/4"	CONDENSATE DRAIN

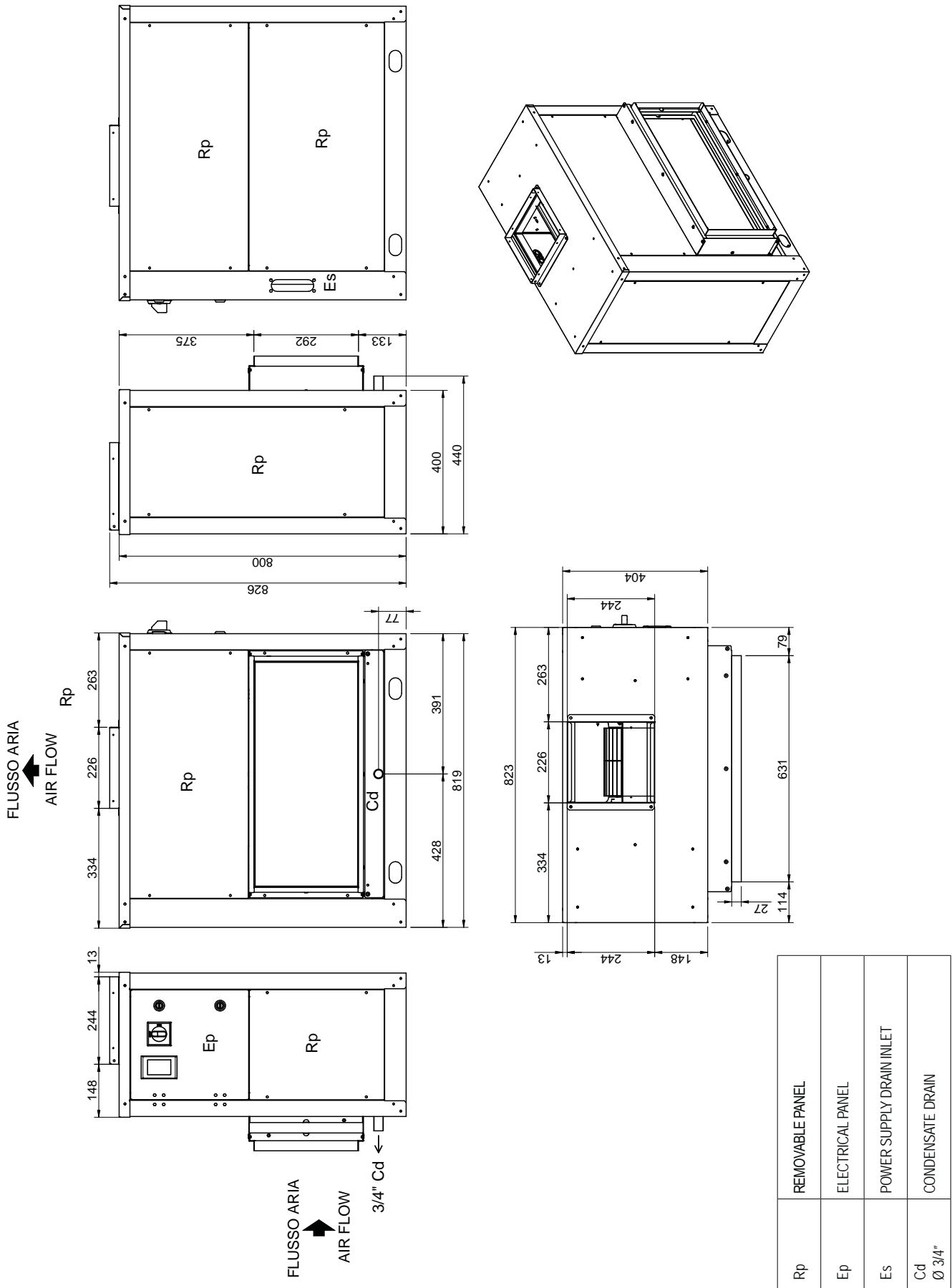

DC 75 - 100 (FARC)

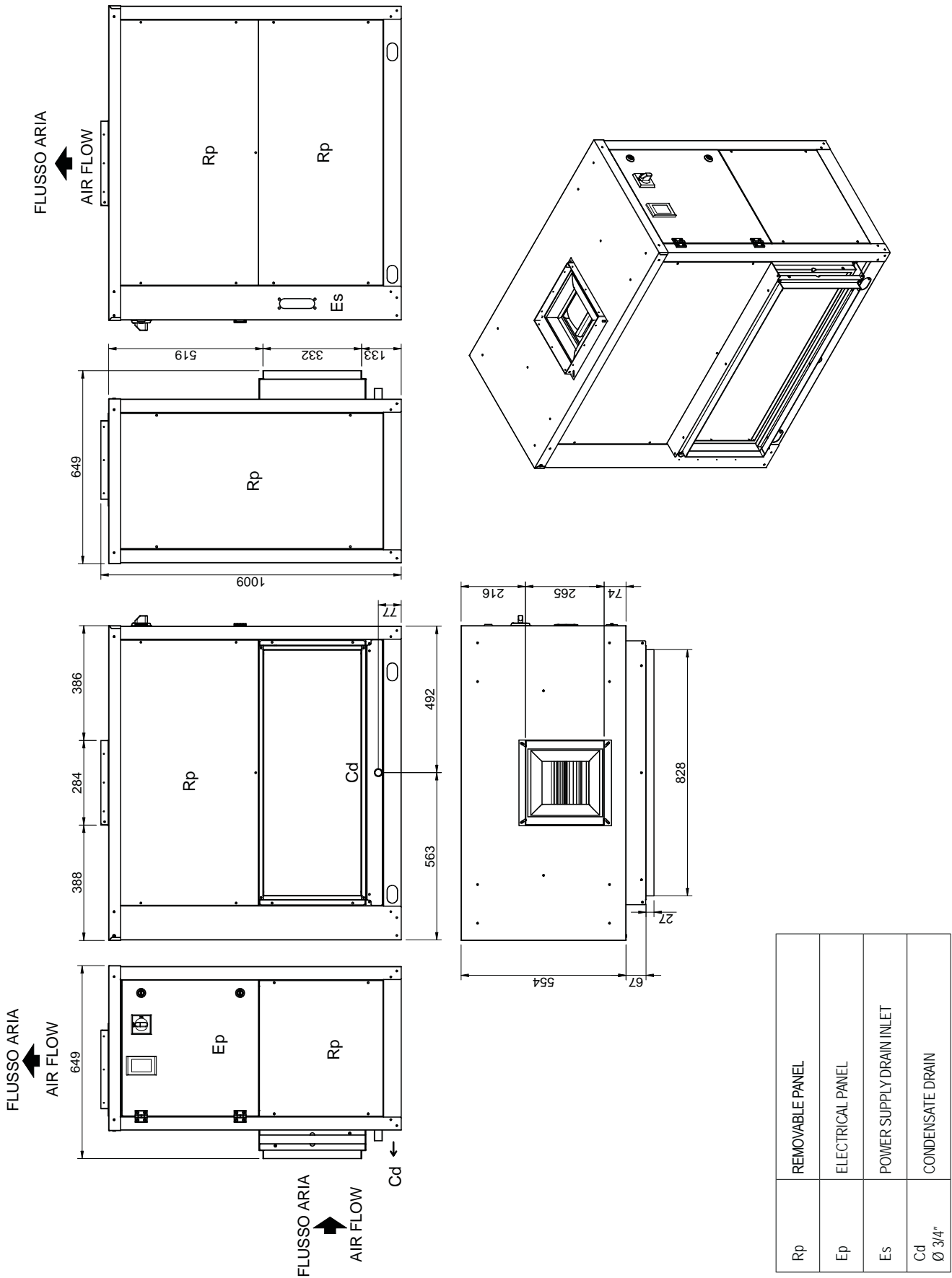

DC 150 - 200 (FARC)



11 . EU DECLARATION OF CONFORMITY

 Condair Group AG Gwattstrasse 17 8808 Pfäffikon Switzerland www.condair.com				DICHIARAZIONE DI CONFORMITÀ UE EU DECLARATION OF CONFORMITY													
Data/Date issuing date		Macchina Modello / Unit Model code and unit description		Numero di serie / Serial number unit serial number													
<p>Noi, firmatari della presente, dichiariamo sotto la nostra esclusiva responsabilità che l'insieme in oggetto, a cui questa dichiarazione si riferisce è conforme a tutte le disposizioni pertinenti delle seguenti direttive ed alle relative normative armonizzate dell'Unione Europea.</p> <p>We, the undersigned, hereby declare under our own responsibility that the assembly in question, to which this declaration refers, complies with all the provisions related to the following directives and harmonised European standards</p> <p>Direttive CEE / EEC directive:</p> <ul style="list-style-type: none"> - 2006/42 EC - 2014/30 EU - 2014/68 EU <p>Normative armonizzate / Harmonised standards:</p> <table> <tr> <td>EN 60204-1:2010</td> <td>EN ISO 13857:2008</td> <td>EN 14276-2:2011</td> </tr> <tr> <td>EN 61000-6-2:2006</td> <td>EN 349:2008</td> <td>EN 13136:2005</td> </tr> <tr> <td>EN 61000-6-4:2007</td> <td>EN 378-2:2012</td> <td>EN 12735-1:2016</td> </tr> <tr> <td>EN ISO 12100:2010</td> <td>EN 14276-1:2011</td> <td>EN 12735-2:2016</td> </tr> </table>						EN 60204-1:2010	EN ISO 13857:2008	EN 14276-2:2011	EN 61000-6-2:2006	EN 349:2008	EN 13136:2005	EN 61000-6-4:2007	EN 378-2:2012	EN 12735-1:2016	EN ISO 12100:2010	EN 14276-1:2011	EN 12735-2:2016
EN 60204-1:2010	EN ISO 13857:2008	EN 14276-2:2011															
EN 61000-6-2:2006	EN 349:2008	EN 13136:2005															
EN 61000-6-4:2007	EN 378-2:2012	EN 12735-1:2016															
EN ISO 12100:2010	EN 14276-1:2011	EN 12735-2:2016															
<p>Il Costruttore / The Manufacturer</p>  <p>Condair Group AG Robert Merki</p>																	

Maintenance and Service Report

Date _____ Job No. _____ Model _____

Type of Service: Commissioning Maintenance Serial number _____
 F-Gas inspection

Customer No./Name _____ City / Town _____
 Address _____ Phone number _____

Date	Start of work	End of work	Total work time (hours)	Travel time (hours)	Total travel distance (km)

Operating conditions

Measurements

Suction line temperature:	°C				
Liquid line temperature:	°C				
Evaporation pressure:	bar				
Condensation pressure:	bar				
Superheating:	K				
Subcooling:	K				
Outdoor temperature:	°C				
Discharge line temperature at compressor outlet:	°C				
Outlet air temperature/humidity:	°C / % RH				
Inlet air temperatur/humidtiy:	°C / % RH				
Outlet air flow:	m ³ /h				
Inlet air flow:	m ³ /h				

Name and signature of service technician _____ Name and signature upon acceptance of the work _____

Maintenance and Service Report

Date _____ Job No. _____ Model _____

Type of Service: Commissioning Maintenance Serial number _____
 F-Gas inspection

Customer No./Name _____ City / Town _____
 Address _____ Phone number _____

Date	Start of work	End of work	Total work time (hours)	Travel time (hours)	Total travel distance (km)

Operating conditions

Measurements

Suction line temperature:	°C				
Liquid line temperature:	°C				
Evaporation pressure:	bar				
Condensation pressure:	bar				
Superheating:	K				
Subcooling:	K				
Outdoor temperature:	°C				
Discharge line temperature at compressor outlet:	°C				
Outlet air temperature/humidity:	°C / % RH				
Inlet air temperatur/humidtiy:	°C / % RH				
Outlet air flow:	m ³ /h				
Inlet air flow:	m ³ /h				

Name and signature of service technician _____ Name and signature upon acceptance of the work _____

Maintenance and Service Report

Date _____ Job No. _____ Model _____

Type of Service: Commissioning Maintenance Serial number _____
 F-Gas inspection

Customer No./Name _____ City / Town _____
 Address _____ Phone number _____

Date	Start of work	End of work	Total work time (hours)	Travel time (hours)	Total travel distance (km)

Operating conditions

Measurements

Suction line temperature:	°C				
Liquid line temperature:	°C				
Evaporation pressure:	bar				
Condensation pressure:	bar				
Superheating:	K				
Subcooling:	K				
Outdoor temperature:	°C				
Discharge line temperature at compressor outlet:	°C				
Outlet air temperature/humidity:	°C / % RH				
Inlet air temperatur/humidtiy:	°C / % RH				
Outlet air flow:	m ³ /h				
Inlet air flow:	m ³ /h				

Name and signature of service technician _____ Name and signature upon acceptance of the work _____

Maintenance and Service Report

Date _____ Job No. _____ Model _____

Type of Service: Commissioning Maintenance Serial number _____
 F-Gas inspection

Customer No./Name _____ City / Town _____
 Address _____ Phone number _____

Date	Start of work	End of work	Total work time (hours)	Travel time (hours)	Total travel distance (km)

Operating conditions

Measurements

Suction line temperature:	°C				
Liquid line temperature:	°C				
Evaporation pressure:	bar				
Condensation pressure:	bar				
Superheating:	K				
Subcooling:	K				
Outdoor temperature:	°C				
Discharge line temperature at compressor outlet:	°C				
Outlet air temperature/humidity:	°C / % RH				
Inlet air temperatur/humidtiy:	°C / % RH				
Outlet air flow:	m³/h				
Inlet air flow:	m³/h				

Name and signature of service technician

Name and signature upon acceptance of the work

Maintenance and Service Report

Date _____ Job No. _____ Model _____

Type of Service: Commissioning Maintenance Serial number _____
 F-Gas inspection

Customer No./Name _____ City / Town _____
 Address _____ Phone number _____

Date	Start of work	End of work	Total work time (hours)	Travel time (hours)	Total travel distance (km)

Operating conditions

Measurements

Suction line temperature:	°C				
Liquid line temperature:	°C				
Evaporation pressure:	bar				
Condensation pressure:	bar				
Superheating:	K				
Subcooling:	K				
Outdoor temperature:	°C				
Discharge line temperature at compressor outlet:	°C				
Outlet air temperature/humidity:	°C / % RH				
Inlet air temperatur/humidtiy:	°C / % RH				
Outlet air flow:	m ³ /h				
Inlet air flow:	m ³ /h				

Name and signature of service technician

Name and signature upon acceptance of the work

Maintenance and Service Report

Date _____ Job No. _____ Model _____

Type of Service: Commissioning Maintenance Serial number _____
 F-Gas inspection

Customer No./Name _____ City / Town _____
 Address _____ Phone number _____

Date	Start of work	End of work	Total work time (hours)	Travel time (hours)	Total travel distance (km)

Operating conditions

Measurements

Suction line temperature:	°C				
Liquid line temperature:	°C				
Evaporation pressure:	bar				
Condensation pressure:	bar				
Superheating:	K				
Subcooling:	K				
Outdoor temperature:	°C				
Discharge line temperature at compressor outlet:	°C				
Outlet air temperature/humidity:	°C / % RH				
Inlet air temperatur/humidtiy:	°C / % RH				
Outlet air flow:	m ³ /h				
Inlet air flow:	m ³ /h				

Name and signature of service technician _____ Name and signature upon acceptance of the work _____

CONSULTING, SALES AND SERVICE:



CH94/0002.00

Condair Group AG
Gwattstrasse 17, CH-8808 Pfäffikon (SZ)
Phone +41 55 416 61 11, Fax +41 55 416 62 62
info@condair.com, www.condair.com

